

A new window to the Sun: The Daniel K Inouye Solar Telescope

The DKIST team



Outline

1. The team & timeline
2. DKIST: a transformational facility
3. DKIST as a multi-wavelength observatory
4. DKIST as a coronagraph
5. DKIST as a polarimeter
6. Instruments

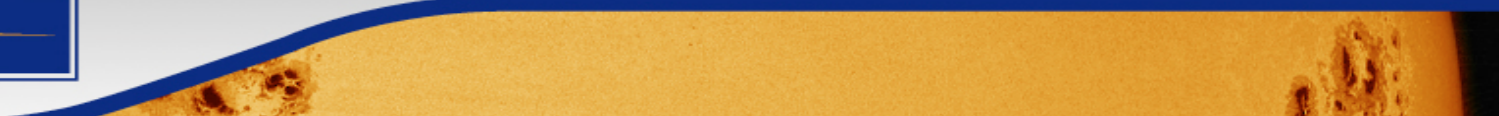

Daniel K Inouye Solar Telescope: The Team

DKIST PI:

NSO/AURA

DKIST Director: T. Rimmele

DKIST co-Is:

P. Goode, M. Knölker,
J. Kuhn, R. Rosner

First light instruments

- NSO
 - VBI PI: F. Wöger
- University of Hawaii, IfA
 - CRYO-NIRSP PI: J. Kuhn
 - DL-NIRSP PI: H. Lin
- High Altitude Observatory
 - ViSP PI: R. Casini
- KIS, Germany,
 - VTF PI: O. vd Luehe
- UK DKIST Consortium
 - Visible Detectors PI: M. Mathioudakis, QUB



Institute for Astronomy
University of Hawaii



The DKIST: status and timeline

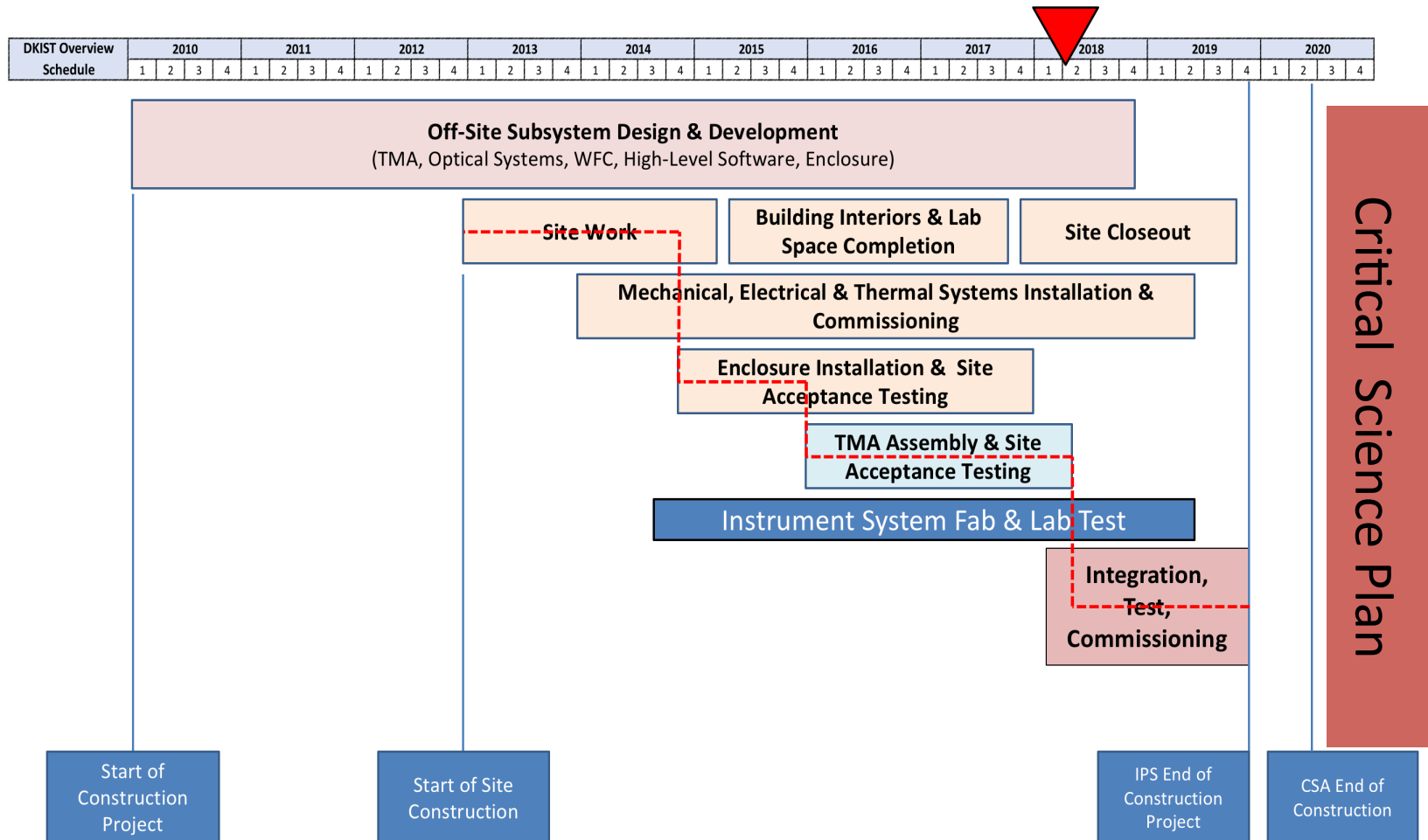

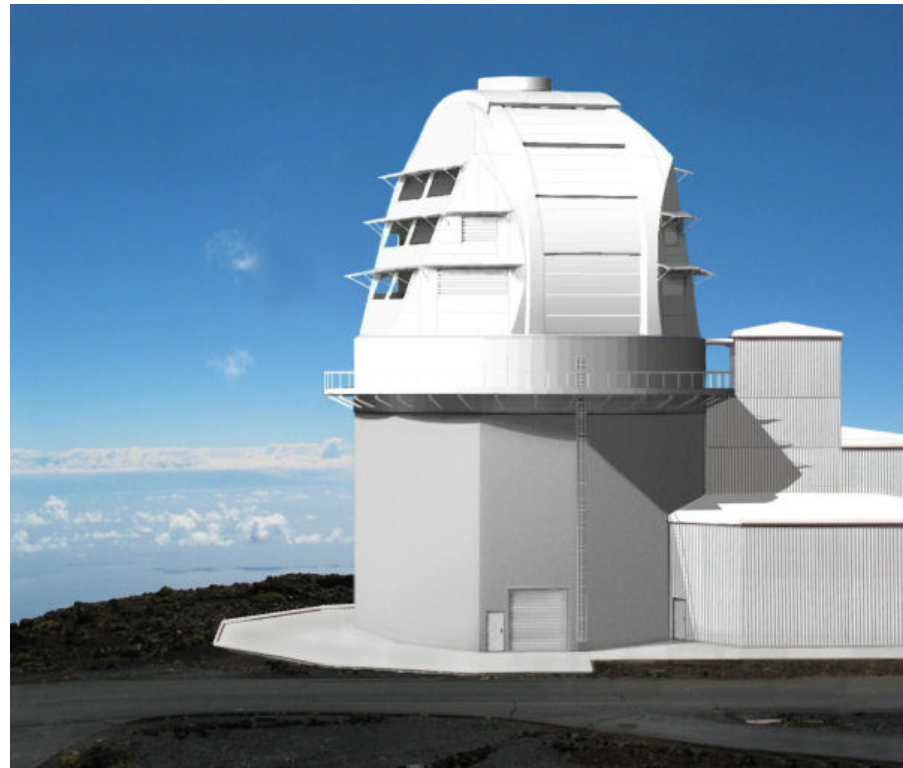

DKIST: a transformational facility

- 4m aperture → 25 km, $SNR \approx 10^4$
- Designed for simultaneous multiline diagnostics
- Designed for accurate and sensitive polarimetry
- Designed for coronal off-limb observations

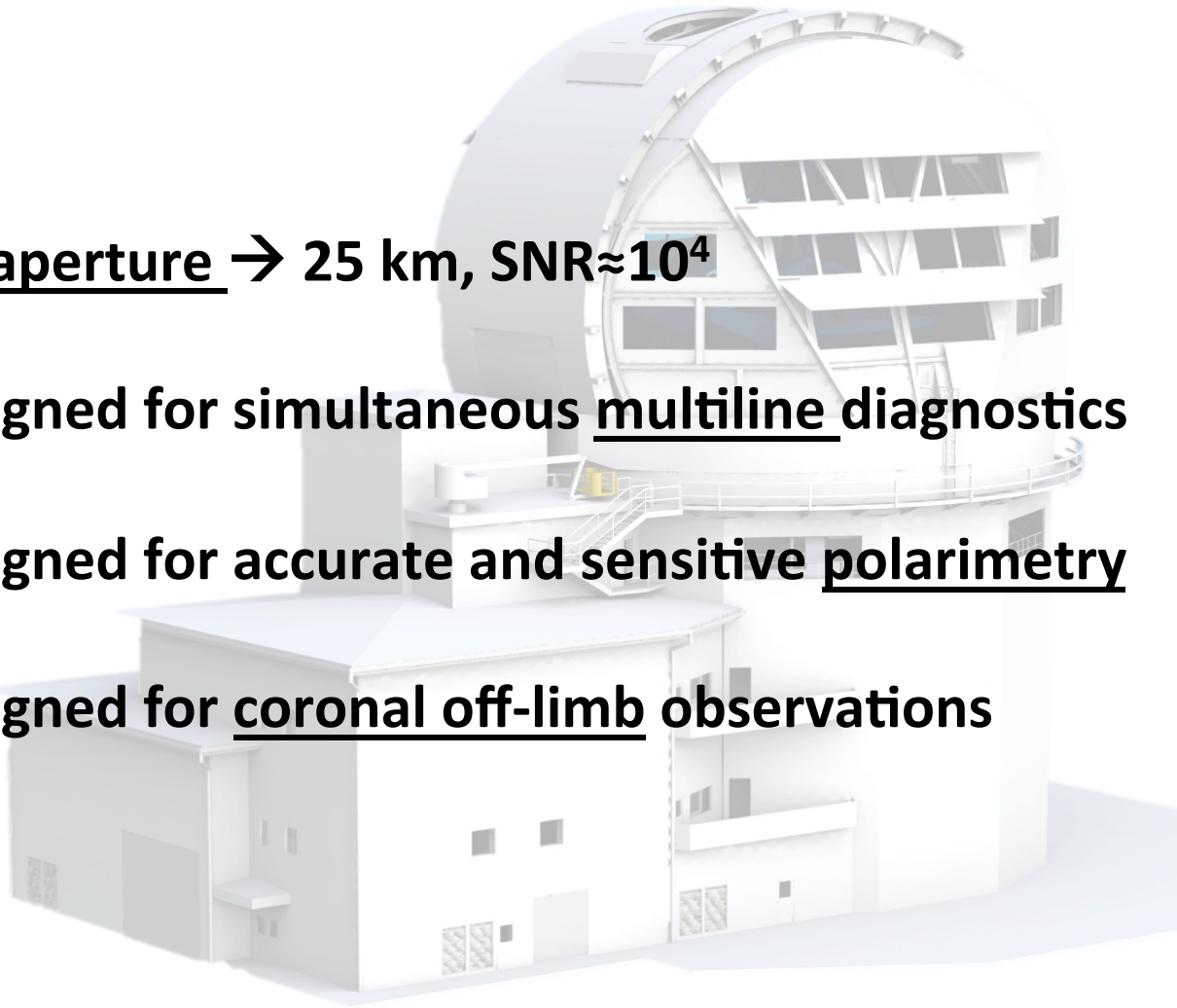

DKIST: a transformational facility

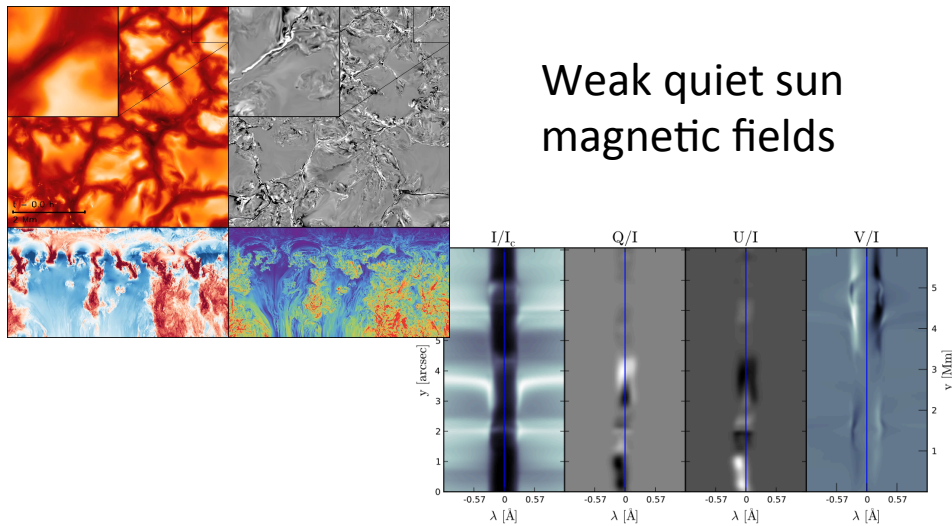

$$SNR \approx 10^4$$

$$\phi_{px} \approx 0.1 \text{ arcsec}$$

$$t_{exp} \approx 10 \text{ s}$$



$$D = \frac{SNR}{\sqrt{0.7 N 10^{-0.4 m} \tau \Delta \lambda Q \phi_{px}^2 t_{exp}}}$$



DKIST: a transformational facility

- Four-meter aperture, f/2
- Alt/azimuth mount
- All reflecting optics
- Off-axis design (no spider, no central obscuration)
- Heat stop at prime focus: hard limit of 5' FOV
- Low-scattered light
 - Coronagraph
 - Lyot stop & limb occulter
 - In situ clean & wash of M1
- Integrated adaptive optics (on-disk)
- High-precision polarimetry
- Thermally controlled environment.
- Service Mode: PI not present.
- Data available on-line: Boulder DC

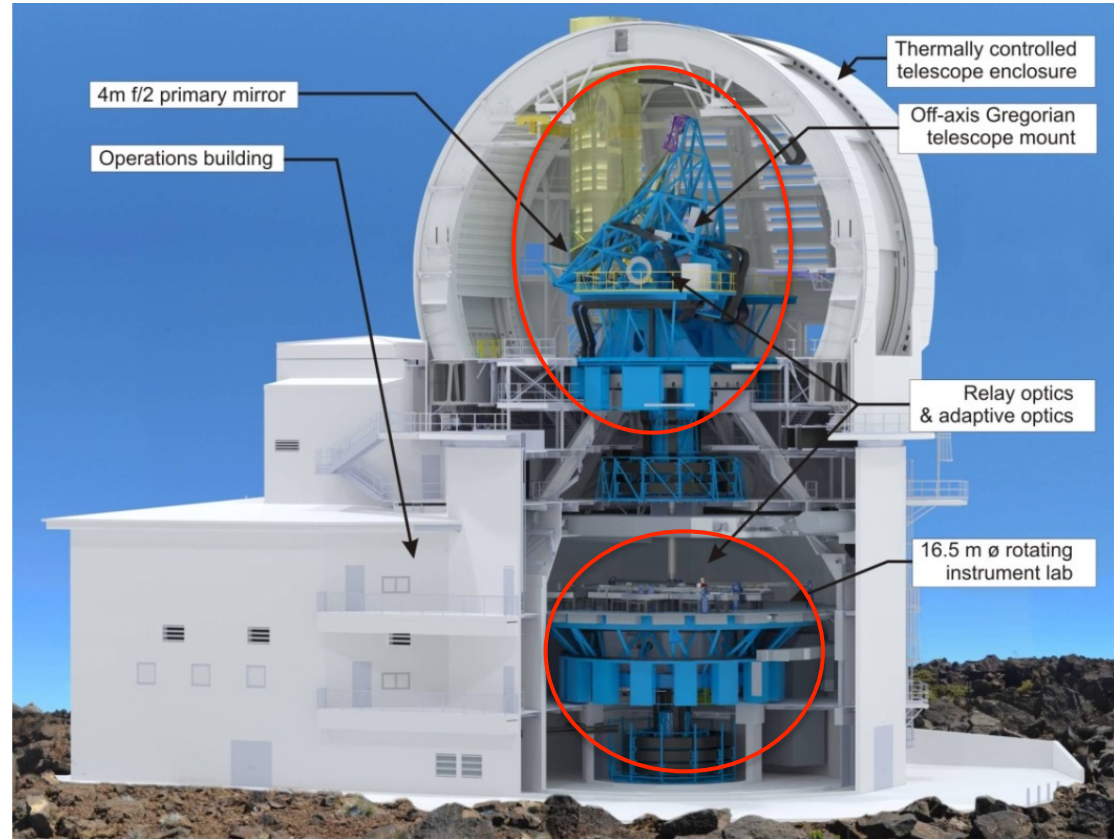

Optical Light Path

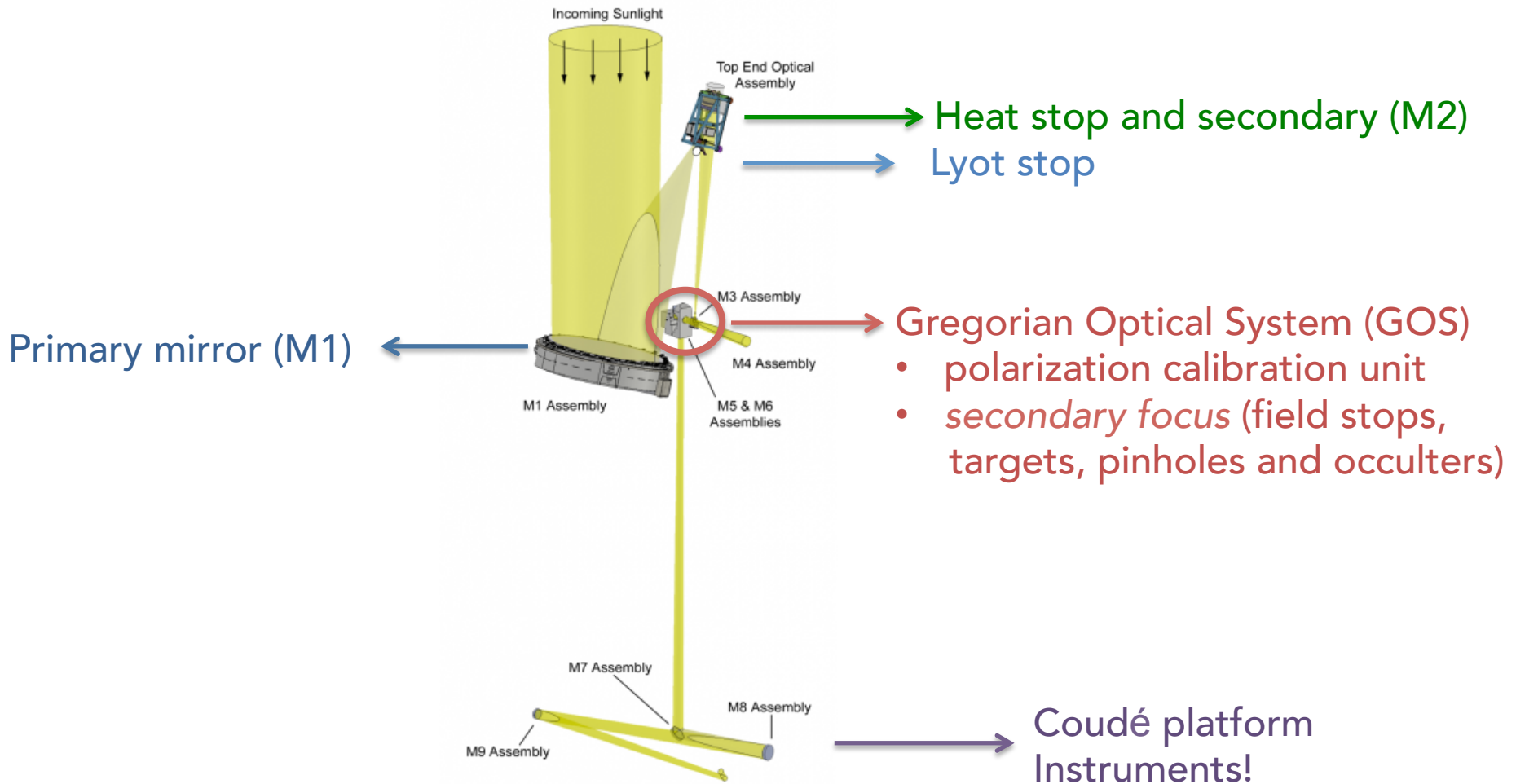

DKIST: a transformational facility



Coudé
Rotator

Telescope
Mount

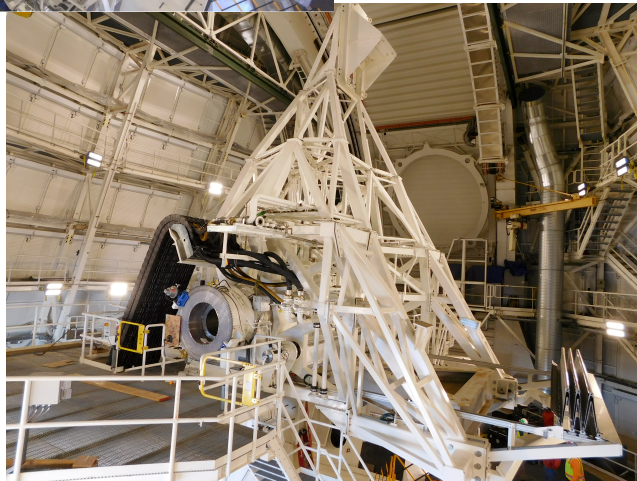

DKIST as a multi-wavelength observatory

nominal: 0.38 – 28 μm ; first light: up to 5 μm

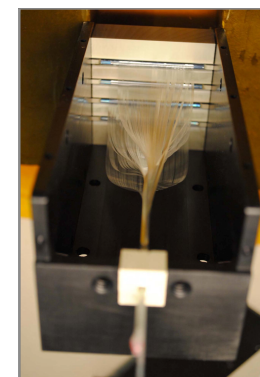
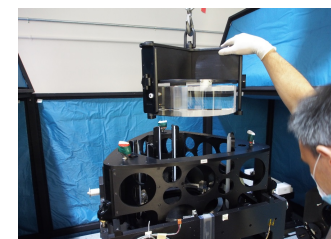
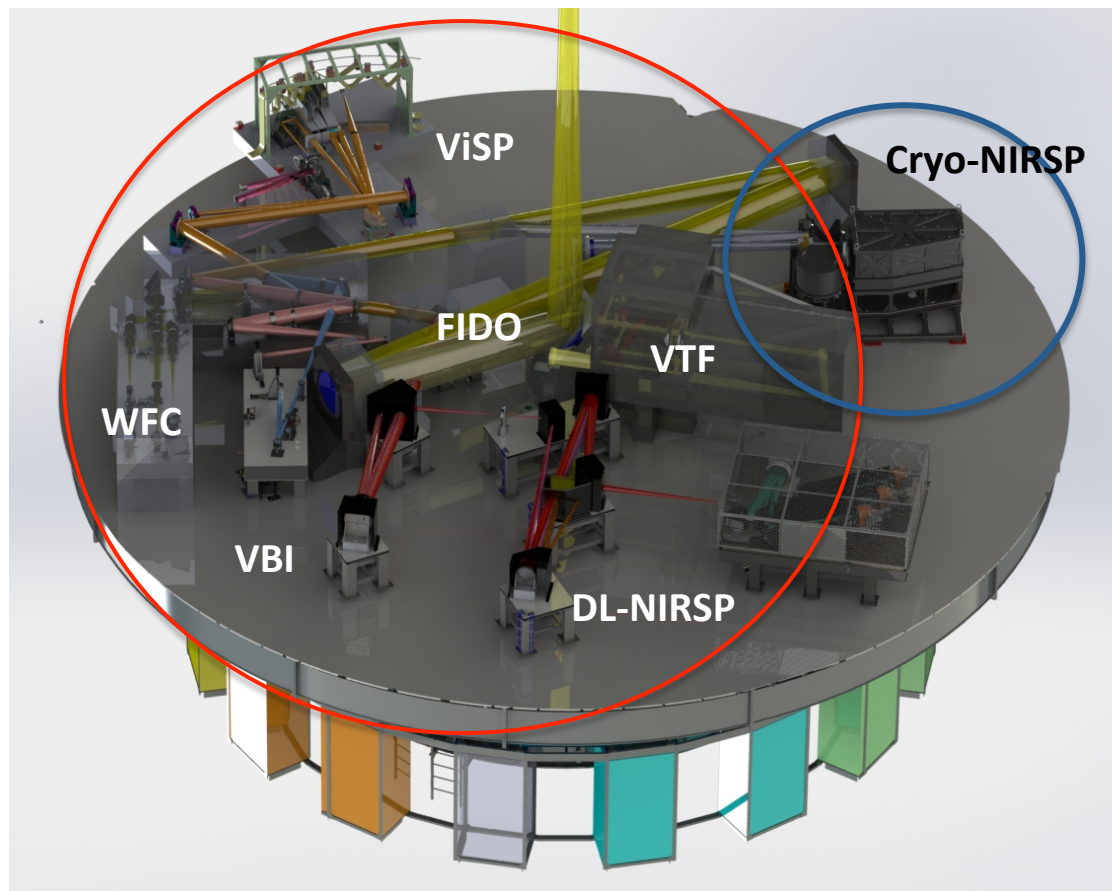
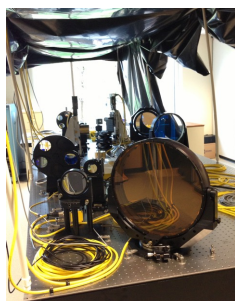
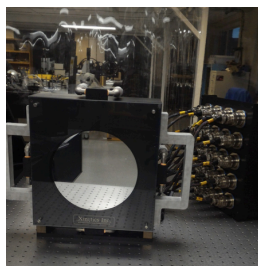
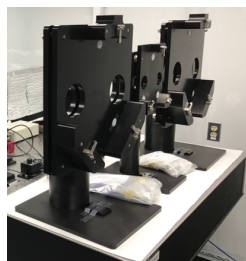

diverse spectral coverage; diagnostics covering entire solar atmosphere
Multi-instrument operations

DKIST as a coronagraph

Wailea



Haleakala



Haleakala +
DKIST+CryoNIRSP

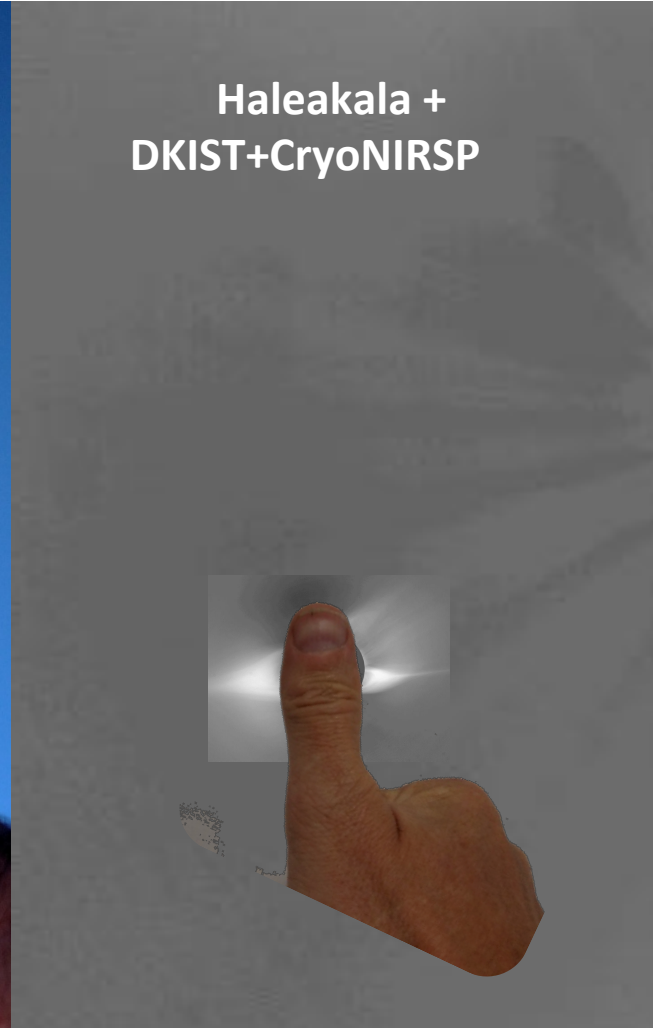

DKIST as a coronagraph



High-grade polished M1 (~ 1 nm)

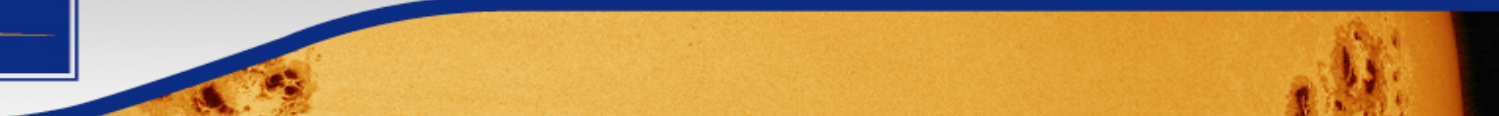

DKIST as a coronagraph

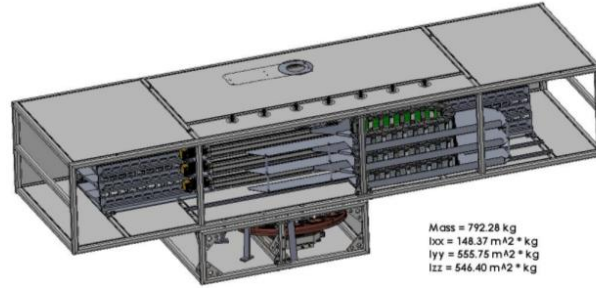
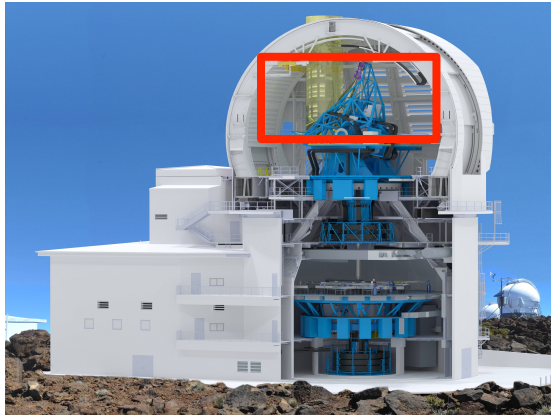

Moss = 792.28 kg
 box = 148.37 mA2 * kg
 lyy = 555.75 mA2 * kg
 lzz = 546.40 mA2 * kg

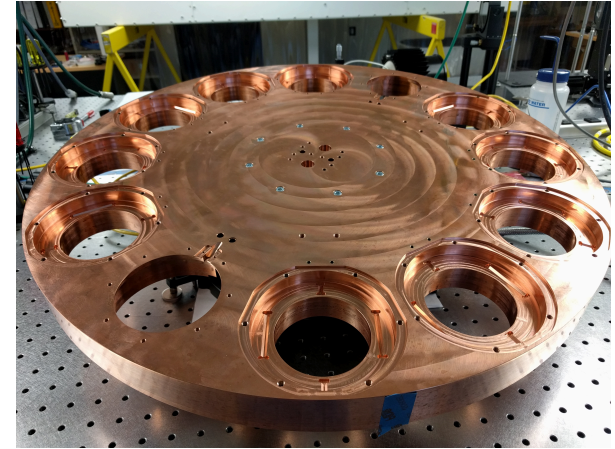

Lyot stop and limb occulters (5' or 2.8'; round)

- How close?: 1 arcsec (depends).
- How far from the limb? $0.5 R_{\odot}$ max.

The Gregorian Optical System (GOS)

- Limb occulter: Disc(s) to block the solar disc near the limb.
- Limb over/under-occluding of ± 5 arcsec possible.
- Comes with a "limb sensor" that measure limb motions.
- Drives M2 for image stabilization.

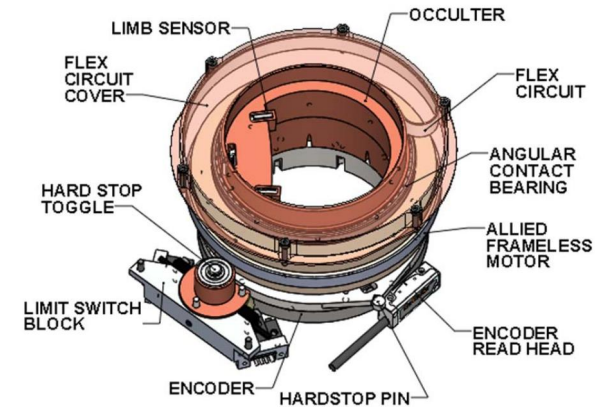

Occulting the Limb

5 arcmin occulter

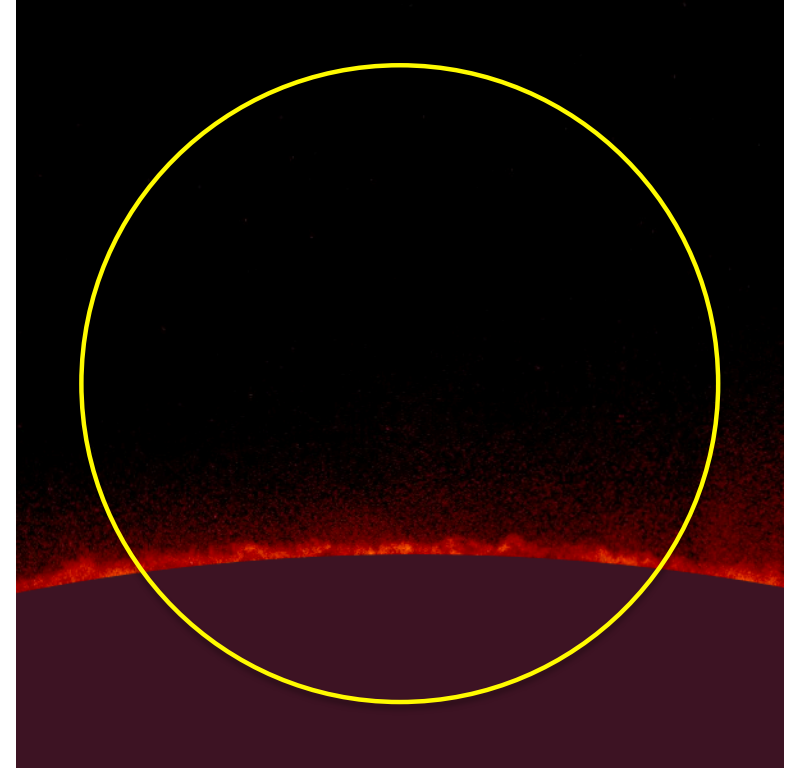
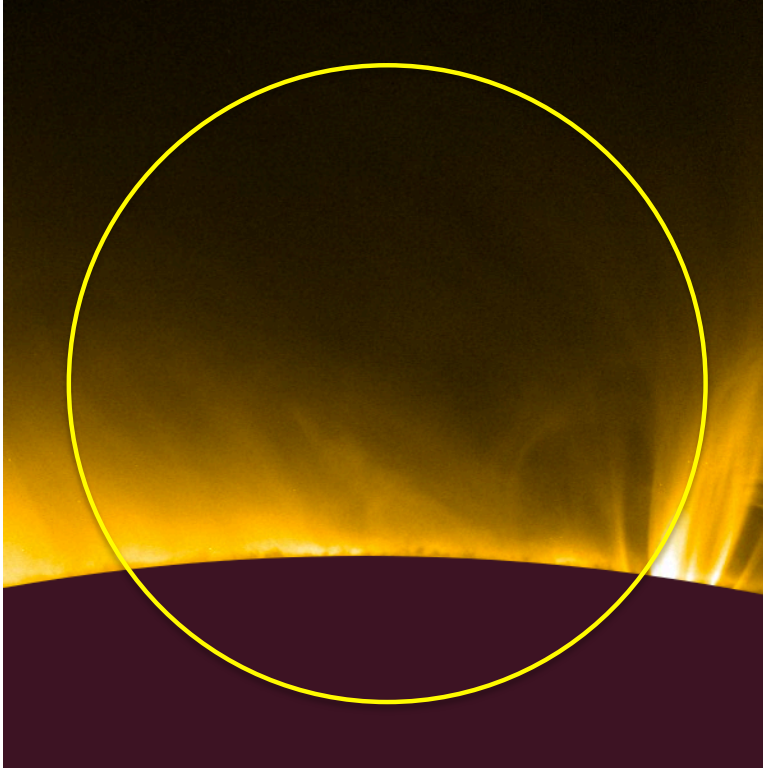

$\pm 5''$

- Limb sensor tracks image motion in both axes, corrected by M2 fast tip/tilt.
- Over/under occultation possible by +/- 5 arcsec.

DKIST as a coronagraph

Coronal observations and diagnostics in the IR (and visible) for DKIST first light

Cryo-NIRSP

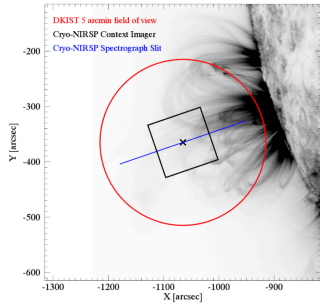

DL-NIRSP

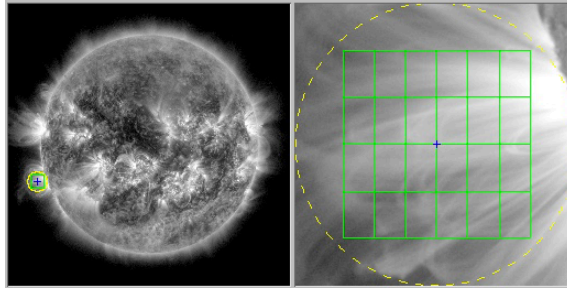

VBI

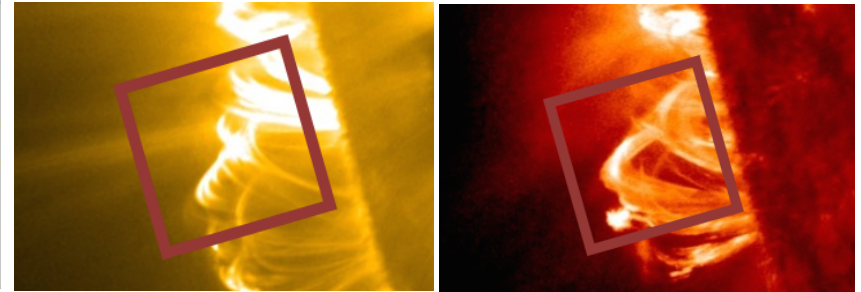

Maximum FOV: 5 arcmin

Cryo-NIRSP Spectropolar.

Fe XIII λ 10747
Fe XIII λ 10797
He I λ 10830
Si X λ 14300
Si IX λ 39350

Cryo-NIRSP Context Imager

Fe XIII λ 10747
He I λ 10830
Si IX λ 39340

Maximum FOV: 2.8 arcmin -- Multi-Instrument Operations

DL-NIRSP Spectropolarimetry

Fe XI λ 7892
Fe XIII λ 10747
Fe XIII λ 10797
He I λ 10830
Si X λ 14300

VBI Imaging

Fe XI λ 7892

VISP Spectropolarimetry

Various lines: 380 to 900 nm

- Emphasis on bright line observations with greatest magnetic field sensitivity and IR.
- Corresponding peak temperature coverage: 1 to 1.6 MK.

DKIST as a Polarimeter

$$\bar{M}_{DKIST} = \bar{M}_7 \bar{R}(Az - Table) \bar{M}_{56} \bar{R}(EI) \bar{M}_{34} \bar{M}_{12}$$

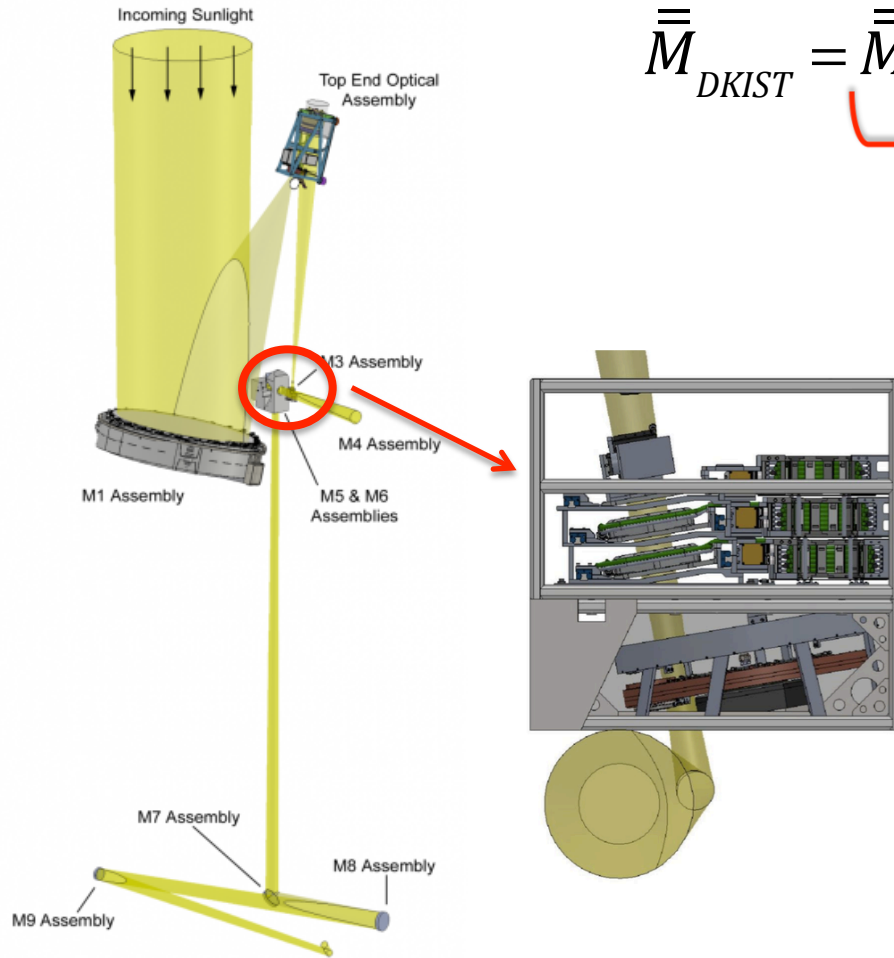

- Polarization sensitivity 10^{-5}
- Polarization accuracy $5 \cdot 10^{-4}$
- Cal optics after M_{12} close to Gregorian Focus.
- Calibrates all optics downstream.
- Similar to Gregor.
- Exposure time dependent.

DKIST as a Polarimeter

$$\bar{\bar{M}}_{DKIST} = \bar{\bar{M}}_7 \bar{\bar{R}}(Az - Table) \bar{\bar{M}}_{56} \bar{\bar{R}}(El) \bar{\bar{M}}_{34} \underbrace{\bar{\bar{M}}_{12}}$$

Powered Optics & Aperture Averaging

1.00000	0.00461	0.00000	0.00000
0.00461	1.00000	0.00000	0.00000
0.00000	0.00000	0.99626	-0.08624
0.00000	0.00000	0.08624	0.99626

1.00000	0.00449	0.00000	0.00000
0.00449	0.99905	0.00000	0.00000
0.00000	0.00000	0.99552	-0.08471
0.00000	0.00000	0.08477	0.99457

0	0.00012	0	0
0.00012	0.00095	0	0
0	0	0.00074	0.00153
0	0	0.00147	0.00169

Diattenuation & retardance differ
Diagonal terms lower than expected
400nm, Al+Al₂O₃ on M1, 3-layer Ag on M2

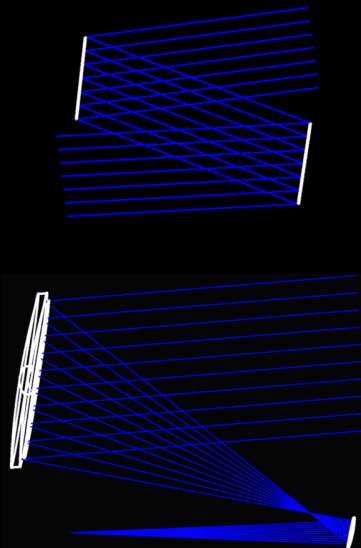

- M_{12} independent of pointing
- Zeemax modeling including coatings.
- Expected $V \rightarrow U$ larger than $V \rightarrow Q$
- Sky polarization.
- Lines with no Q & U: Sun pointing.
- Mirror samples.
- **PolCal is a facility task.**



Instruments

- DKIST instruments are complex, diverse, and rapidly* flexible to support a very broad science portfolio.
- Users must understand and/or make decisions about:
 1. *Telescope field-of-view, pointing sequences, mosaics, coronagraphy, etc.*
 2. *Instrument lab rotation angle (solar image rotation)*
 3. *(Manually-changed) spectral distribution of light to instruments.*
 4. *Spectral/imaging/polarimetric capabilities of facility instruments*
 5. *Instrument parameters including domain coverage and SNR.*
 6. *Data rate/volume limits.*

1. Telescope field-of-view, pointing sequences, mosaics, and coronagraphy.

- Telescope prime field stop: 5 arcmin diameter.
- Solar pointing limitations: < 1.5 solar radii.
- Gregorian focus field stops: 5 arcmin and 2.8 arcmin, each with a limb-occulting.
- 5 arcmin for Cryo-NIRSP (off-limb corona); 2.8 arcmin for all other instruments.
- Instruments each have separate instantaneous and scanning accessed field of view.
- The telescope can perform an automated pointing sequence of discrete targets, and mosaics (stitching together of a large FOV, adjacent tiles).

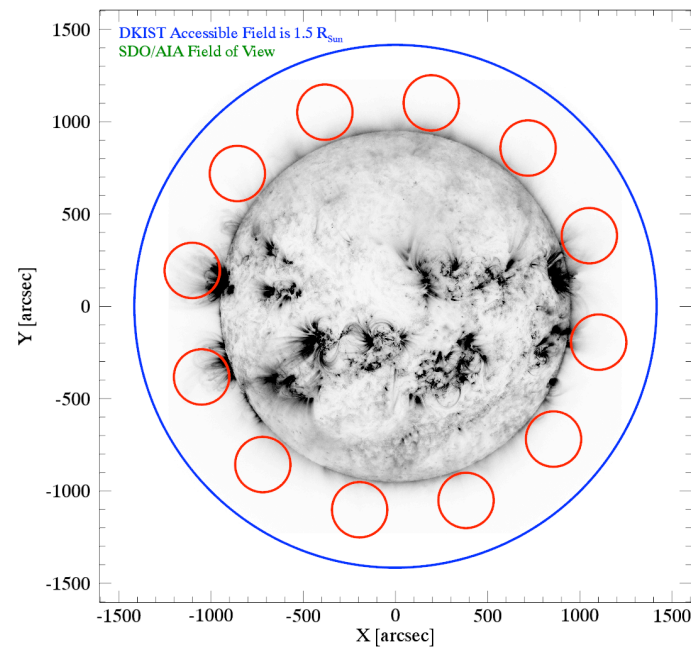
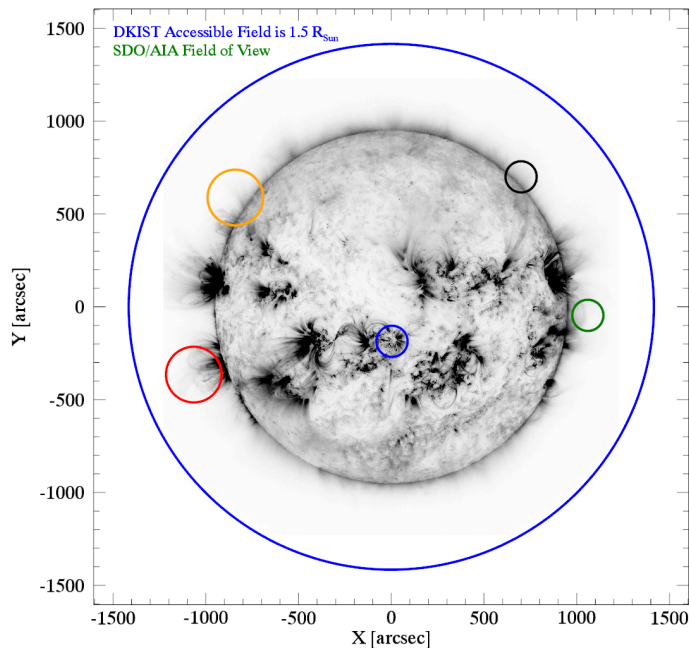

2. The instrument Coudé lab and the field rotation angle

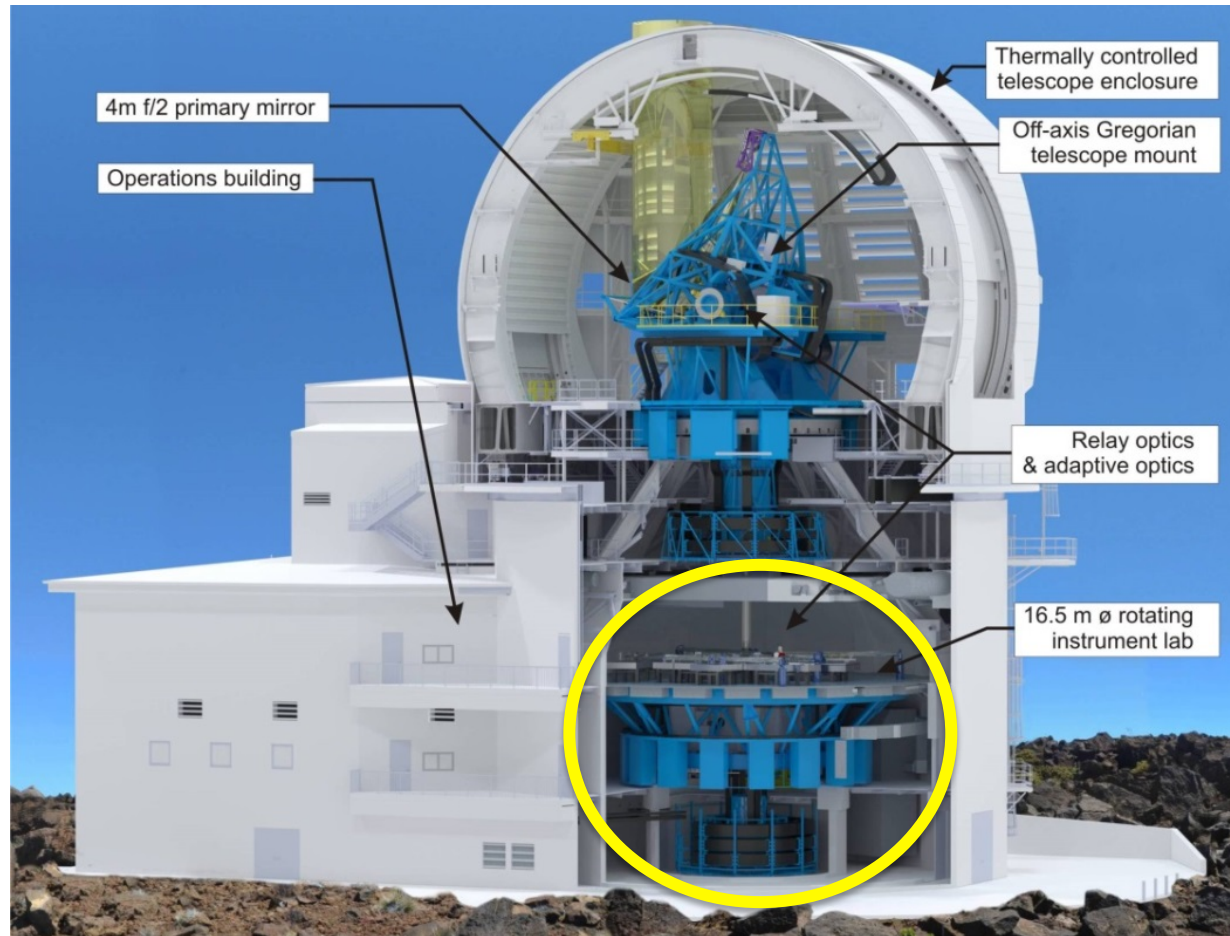

All instruments live in the Coudé instrument Lab and have fixed mountings.

The target's angular orientation with respect to instruments is controlled by the Coudé platform rotation.

Coudé Instrument Lab

- 16.5m rotating instrumental platform
- Clean, environment controlled, externally operated, laboratory.
- Constant rotation compensates mount-induced solar image rotation.
- Can be rotated to orient solar image based on science need, e.g.
 - Slit aligned N/S or E/W
 - Slit parallel/perpendicular to limb.
 - Slit freely aligned parallel to filament axis, polarity inversion line, etc.



Facility Instrument Distribution Optics (FIDO)

- FIDO consists of a suite of mirrors, windows and dichroic beamsplitters downstream of the adaptive optics deformable mirror.
- **All or No Light in a wavelength band”.**
- The dichroics are *interchangeable* for maximum flexibility
- Each individual instrument can also be fed *all* of the light using a mirror and windows.
- A mirror feeding the Cryo-NIRSP can be inserted ahead of AO within some *20-30 minutes* for fast switch-over.
- Changing a dichroic configuration can take up to **one day**
 - Changing of configurations will likely be minimized during DKIST operations.
 - Aim is to establish a list of configurations that are often requested.

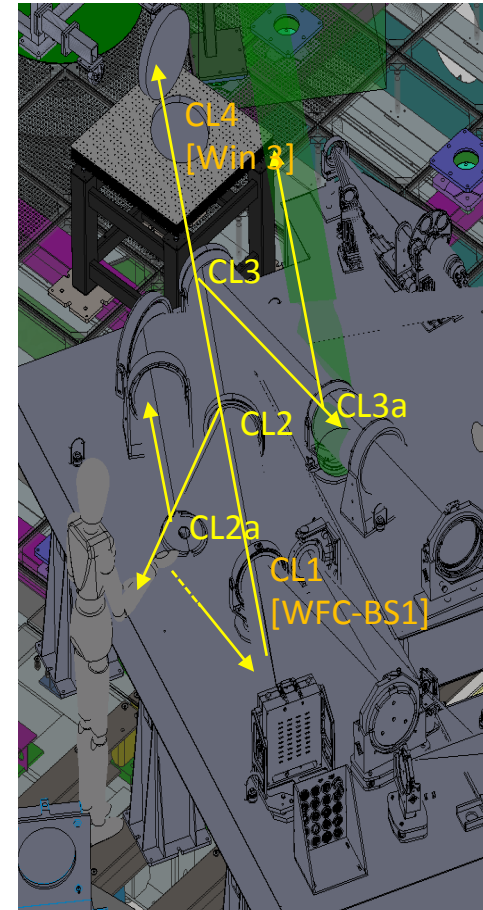

3. Flexible (manually-changed) spectral distribution of light to instruments.

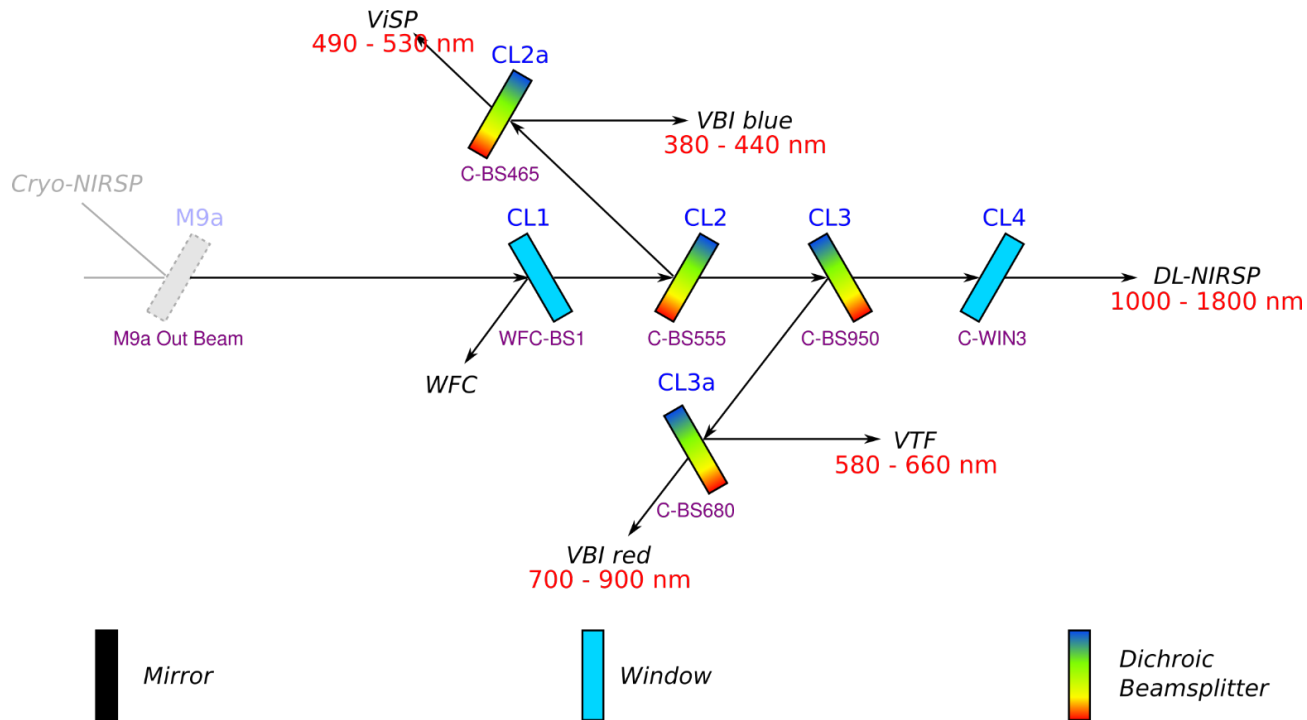

- Shorter wavelengths reflected, longer wavelengths transmitted.
- All instruments except one (Cryo-NIRSP) can be operated at the same time and with AO.

Available beamsplitters/windows

Name	Reflected Band	Transmitted Band	Comment
C-BS465	380 – 440 nm	490 – 1800 nm	Standard Location: CL2A
C-BS555	380 – 530 nm	580 – 1800 nm	Standard Location: CL2
C-BS680	380 – 660 nm	700 – 1800 nm	Standard Location: CL3A
<i>C-BS643</i>	<i>380 – 630 nm</i>	<i>656 – 1800 nm</i>	<i>Procurement is a GOAL</i>
C-BS950	380 – 900 nm	1000 – 1800 nm	Standard Location: CL3
C-WIN1		380 – 900 nm	Transmission band AR coat
C-WIN2		380 – 1800 nm	Uncoated front surface
C-WIN3		500 – 1800 nm	Transmission band AR coat Standard Location: CL4
C-MIR1	380 – 1800 nm		Protected Silver coat

4. Spectral/imaging/polarimetric capabilities of facility instruments

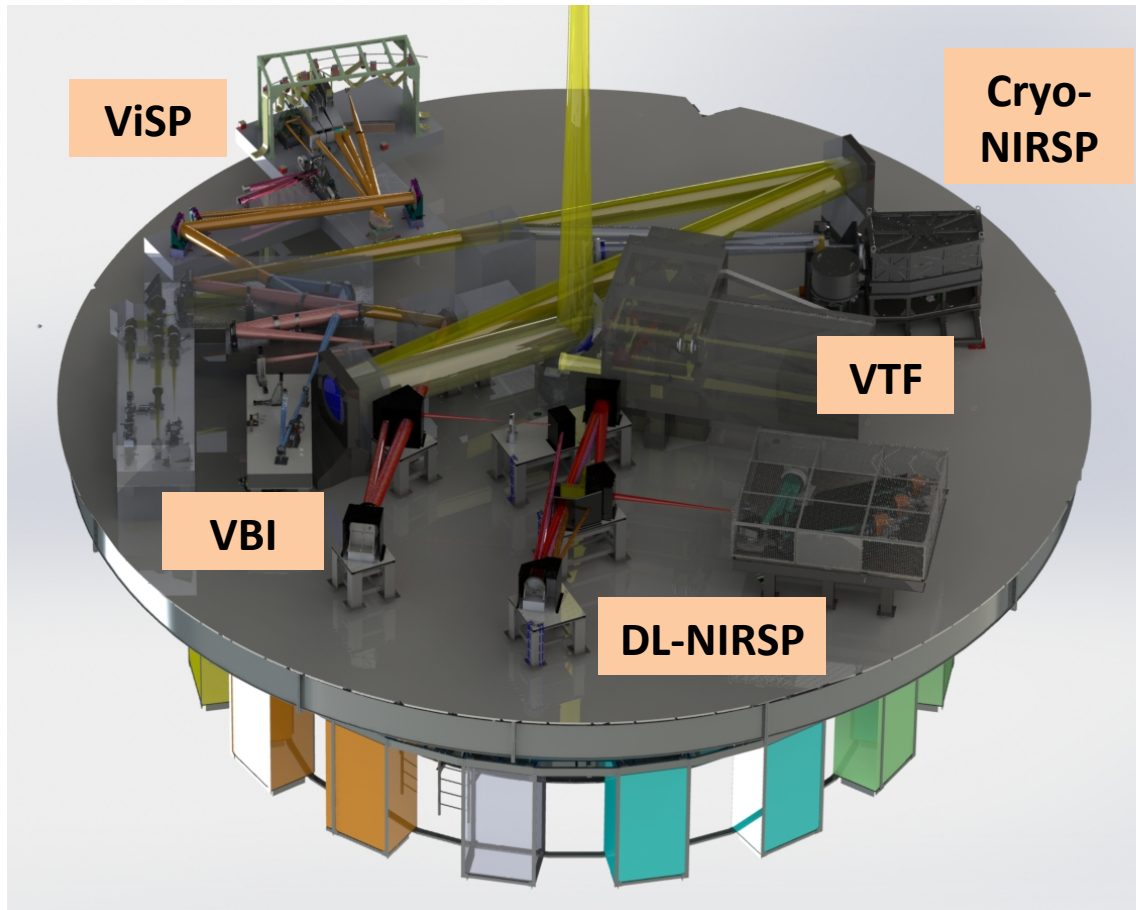

First-Light Instrument Suite

Five complementary image-, slit-, and IFU-based instruments.

Spectropolarimetric focus.

All instruments are fed with a wavefront corrected beam (with exception of Cryo-NIRSP).

DKIST Instrument Suite Overview

Instrument Name	Acronym	Wavelength Range	Analogs
Visible Broadband Imager	VBI (blue, red)	390 – 550 nm 600 – 860 nm	Hinode/BFI; ROSA <i>High cadence, high spatial res.</i>
Visible Spectro-Polarimeter	ViSP	380 – 900 nm	SPINOR, Hinode/SP, IRIS <i>Scanning spectrograph, high spectral fidelity</i>
Diffraction-Limited Near IR Spectro-Polarimeter	DL-NIRSP	500 – 900 nm 900 – 1350 nm 1350 – 1800 nm	SPIES, GRIS-IFU <i>True IFU, variable spatial resolution / FOV</i>
Visible Tunable Filter	VTF	520 – 870 nm (590 – 870 nm)	IBIS, CRISP, GFPI, HMI <i>Imaging spectro-polarimeter</i>
Cryogenic Near IR Spectro-Polarimeter (with context imager)	Cryo-NIRSP	1000 – 5000 nm	CYRA (BBSO) <i>Cryogenic, scanning spectrograph, novel IR diagnostics</i>

Spectral coverage summary

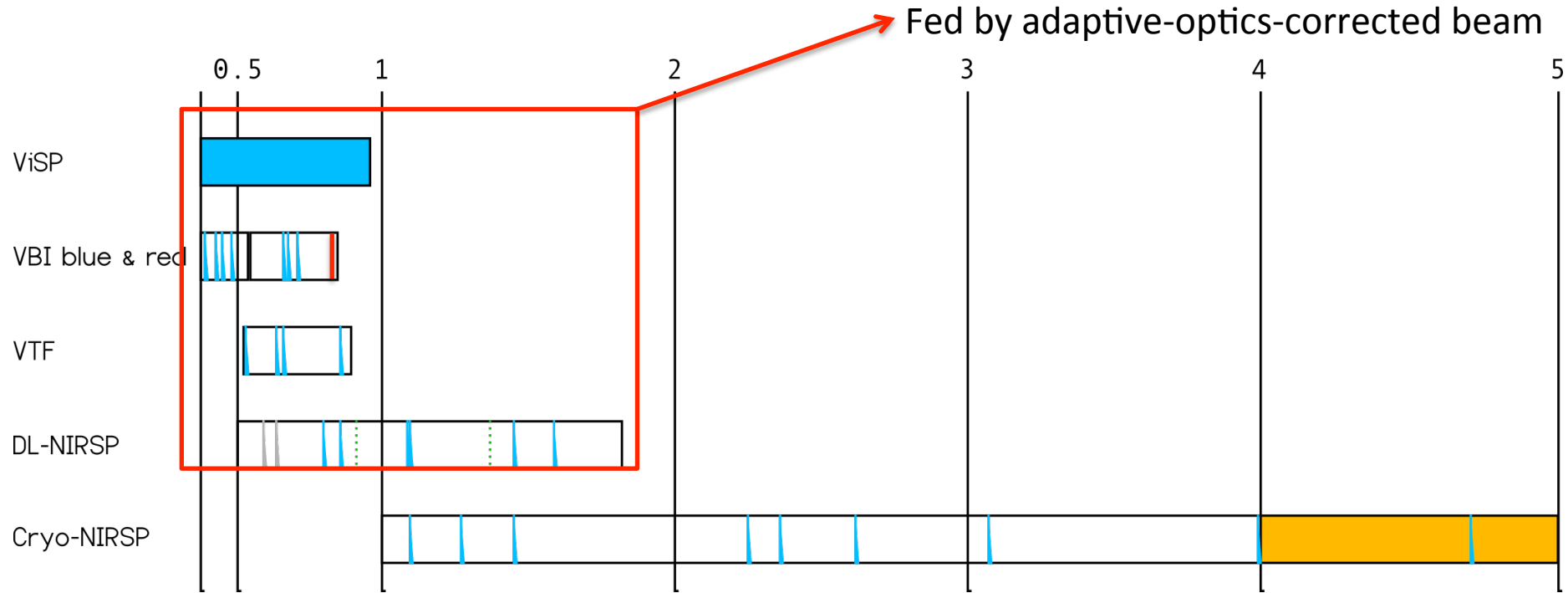

- Instruments – *with the notable exception of the ViSP* – operate at discrete wavelengths, because of the required pre-filters for the instruments.
- Filter availability can be expanded in the future.
- Instruments can work alone, or together (Cryo-NIRSP can only work alone)

Visible Broadband Imager (VBI)

High cadence, high spatial resolution imaging w/ Speckle reconstruction

NSO (PI: Friedrich Wöger)

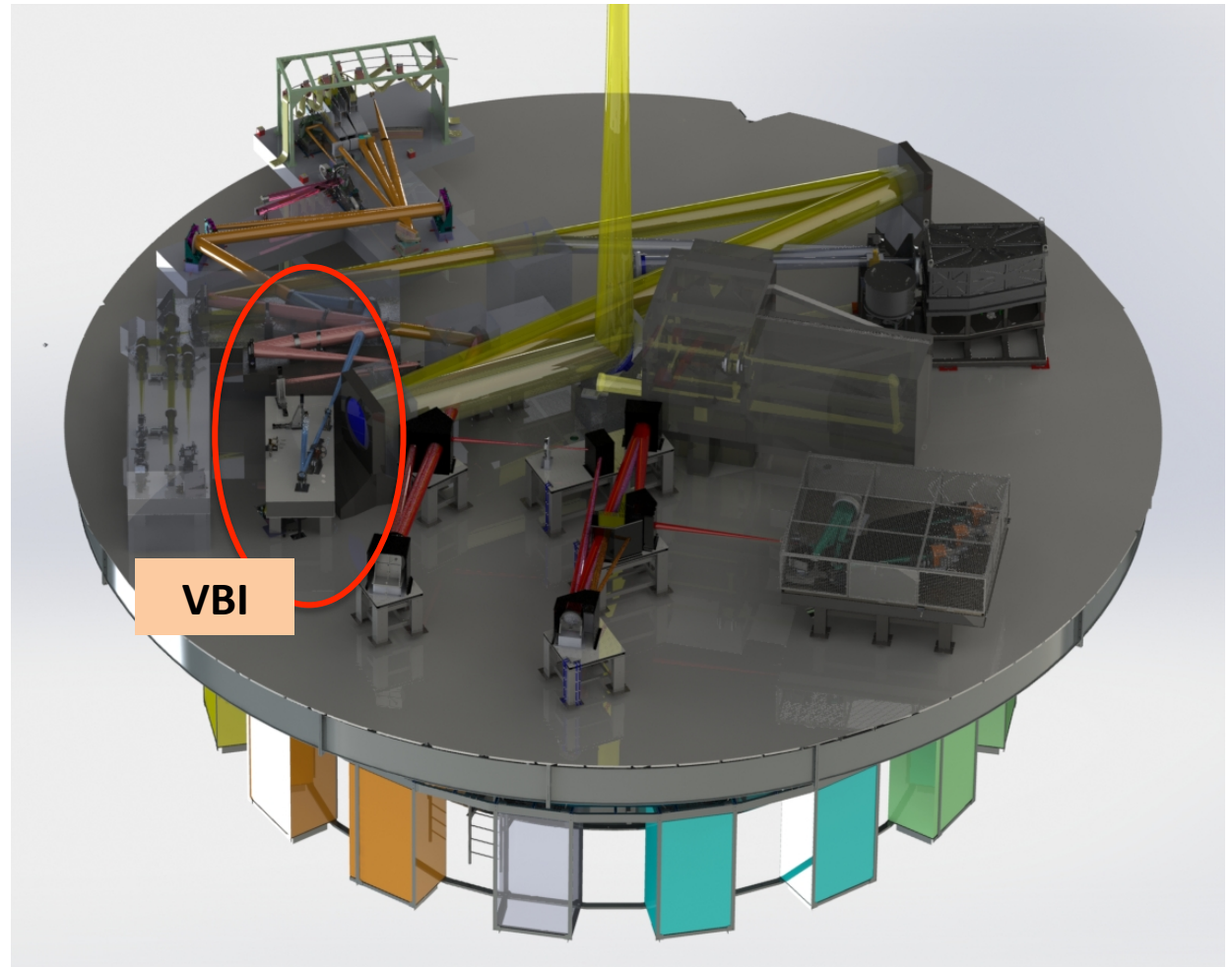
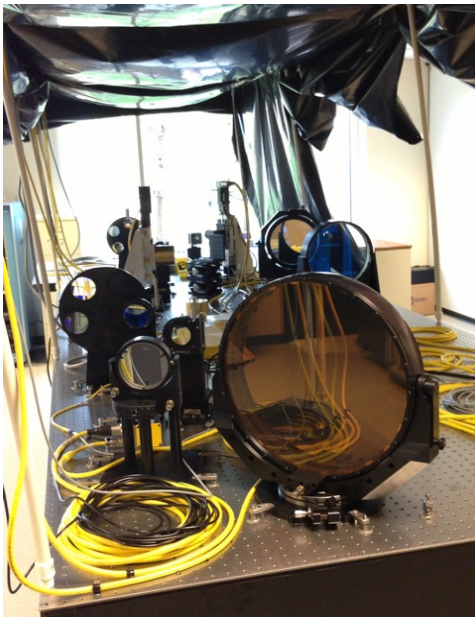

Visible Broadband Imager (VBI)

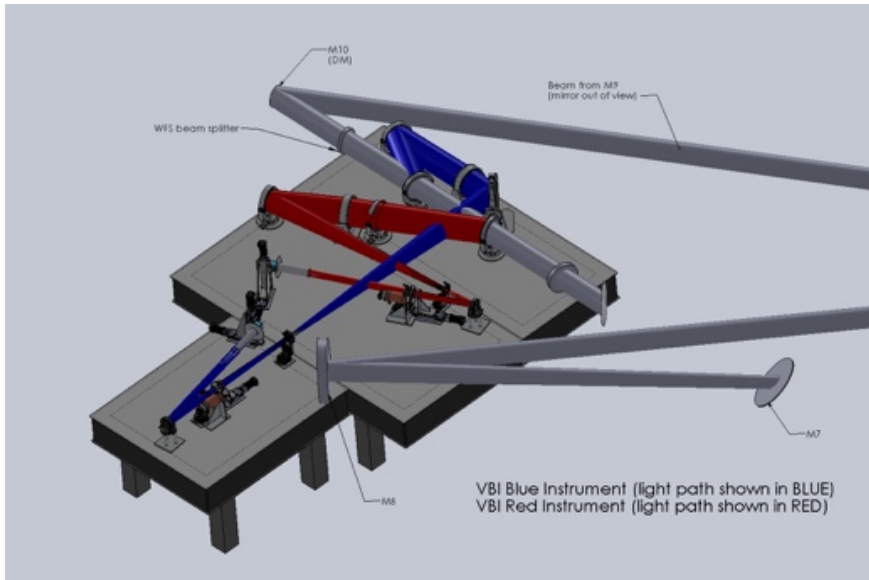

- 2 detectors (channels)
4 filters available in each channel
(0.05 – 0.5 nm FWHM).
- Sequential selection of filters
(within each channel, filter wheel)
- Channels fully independent; can work together or alone
- VBI BLUE (390-550 nm):
CaII K, G-band,
continuum, H-beta
- VBI RED (600-860 nm):
H-alpha, continuum,
TiO, Fe XI 789.2 nm (corona)
- NO polarimetry

Visible Broadband Imager (VBI)

Instantaneous Field of View:

45 x 45 arcsec² (blue channel)

69 x 69 arcsec² (red channel)

Full optical field:

2 x 2 arcmin² – by field sampling:

3 x 3 tiles in blue channel.

2 x 2 tiles in red channel

Spatial sampling:

0.011 arcsec (blue)

0.017 arcsec (red)

Temporal Sampling:

3.2 s for speckle reconstructed images

0.033 s raw images

0.5 s change of FOV

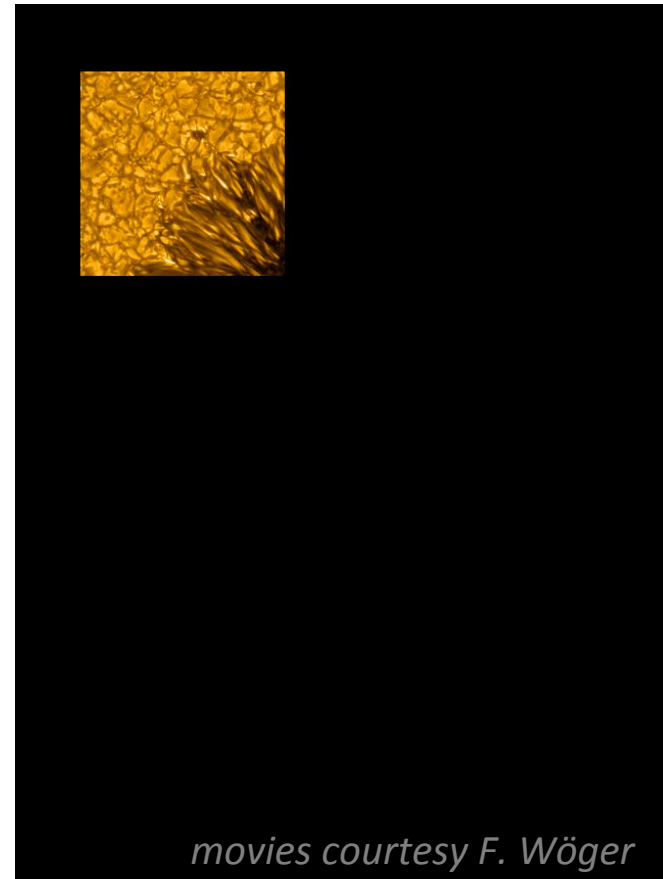

VBI stresses high cadence and high spatial resolution –
will deliver images at the diffraction limit of the telescope

Visible Spectro-Polarimeter (ViSP)

*Scanning slit
spectropolarimeter,
high spectral fidelity,
broad access to well-
established and new
spectral diagnostics*

HAO (PI: Roberto Casini)

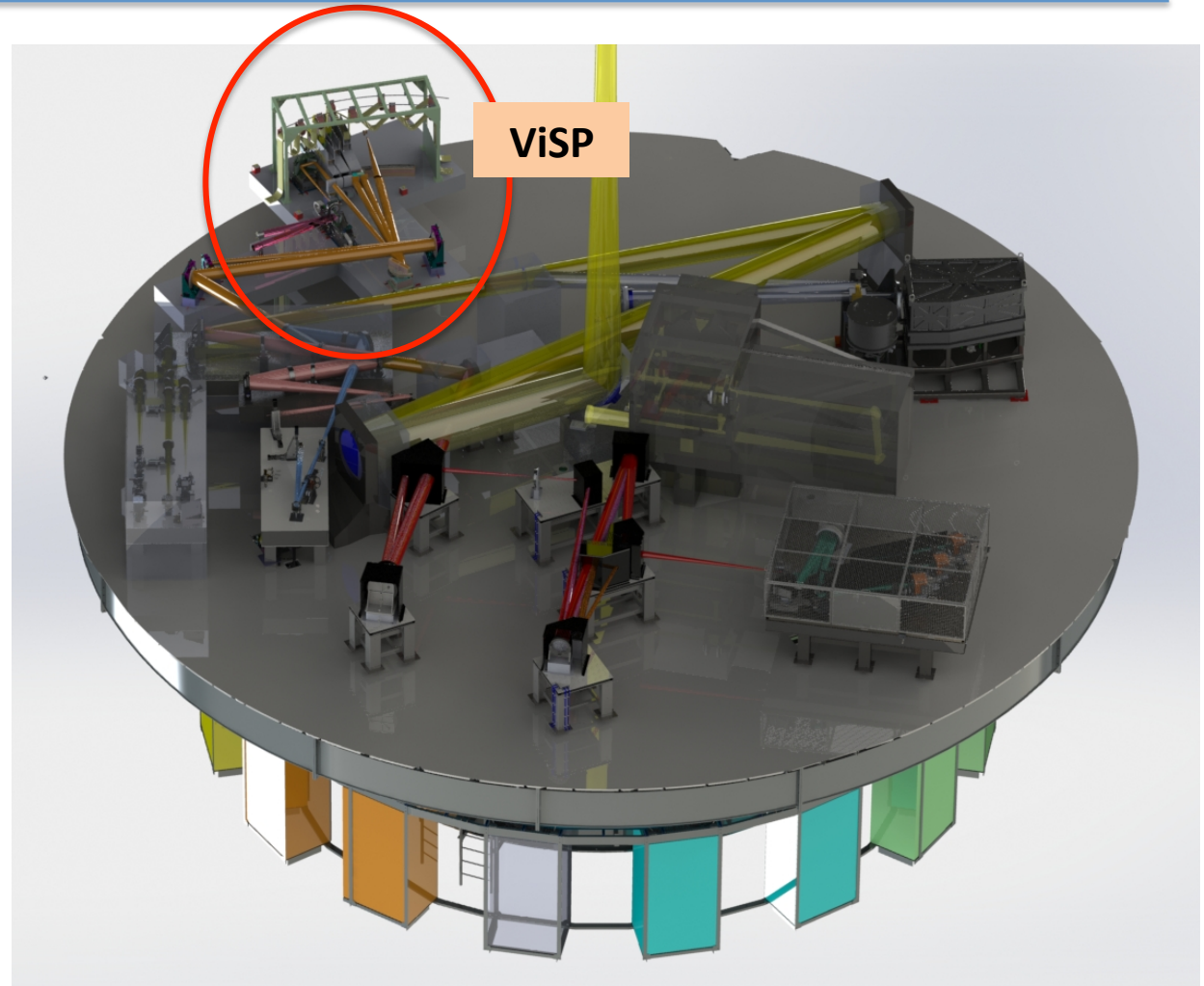
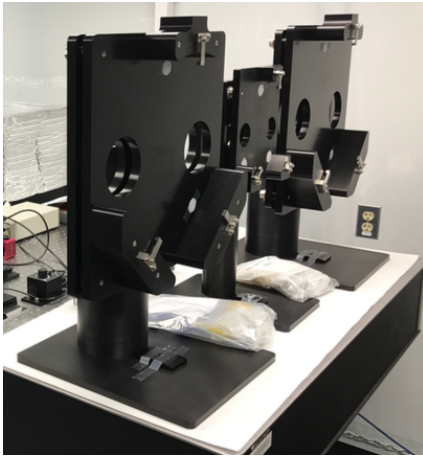

Visible Spectro-Polarimeter (ViSP)

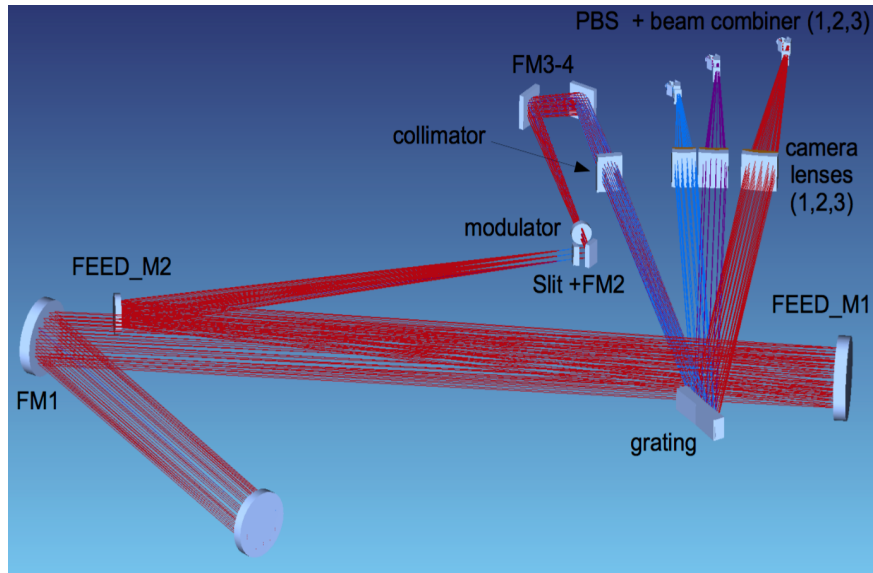

- Diffraction-grating based spectrograph.
- Access to full visible spectrum: 380 – 900 nm.
- 3 distinct “arms”: up to 3 separate spectral bands (~ 1 nm wide) can be observed simultaneously; different spatial and spectral scales.
- ANY portion of the spectrum can be imaged on ANY spectral arm – depending on combination of desired ranges.
- 5 possible slit widths (motorized): from 0.028” to 0.214”.
- Dual beam full Stokes polarimetry.
- Uses VBI blue-channel images for context.

Visible Spectro-Polarimeter (ViSP)

Instantaneous Field of View:

slit width x (75", 60", 50")

Full optical field:

Slit length x 2 arcmin – by slit scanning (slit is moved across solar image).

Spatial sampling:

0.03", 0.0236", 0.0198" (along slit, arms 1-2-3)

Spectral Resolution:

≤ 3.5 pm @ 630 nm or $R \geq 180,000$

Temporal Sampling:

0.5-10 sec per slit position (polarimetry);

0.02-0.2 sec per slit position (spectroscopy)

Polarimetric Capability:

Target Sensitivity: $10^{-3} P/I_{\text{cont}}$ in 10 sec

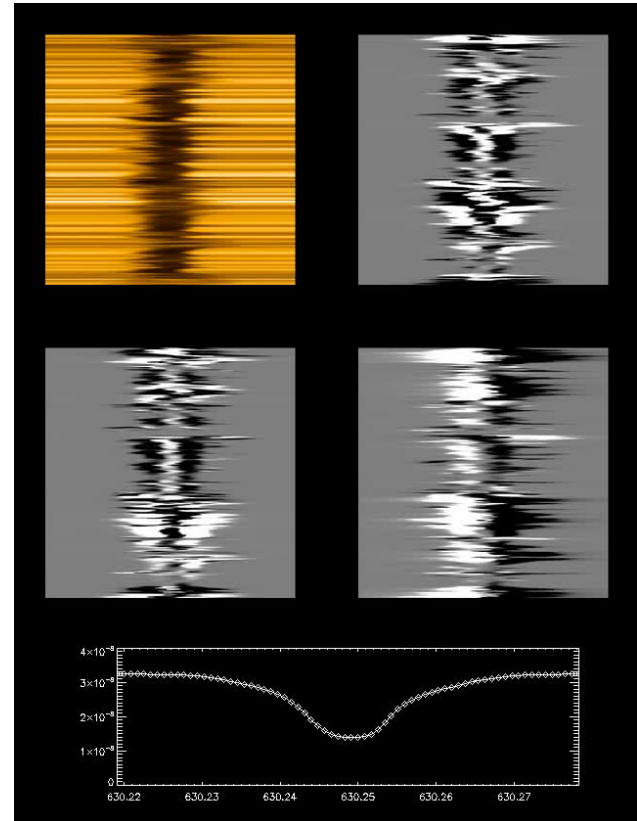

ViSP stresses high spectral fidelity and flexibility—
will deliver high precision spectro-polarimetry

Visible Tunable Filter (VTF)

Fast-tuning, narrowband imaging spectro-polarimeter, high fidelity spectro-imaging with great coverage of temporal dynamics.

KIS (PI: Oskar von der Luehe)

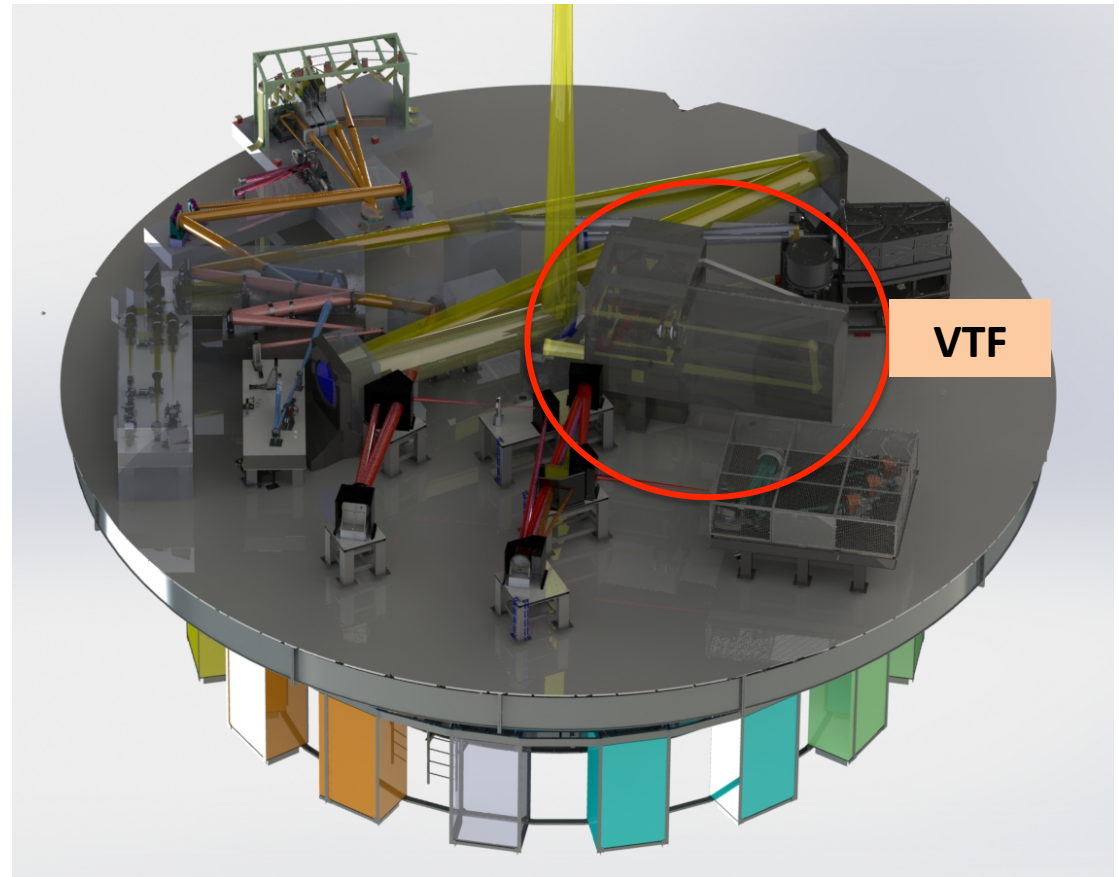
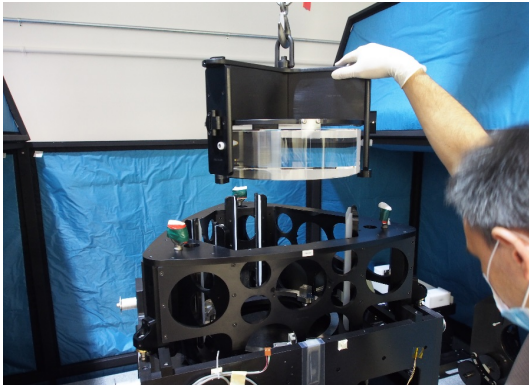

Visible Tunable Filter (VTF)

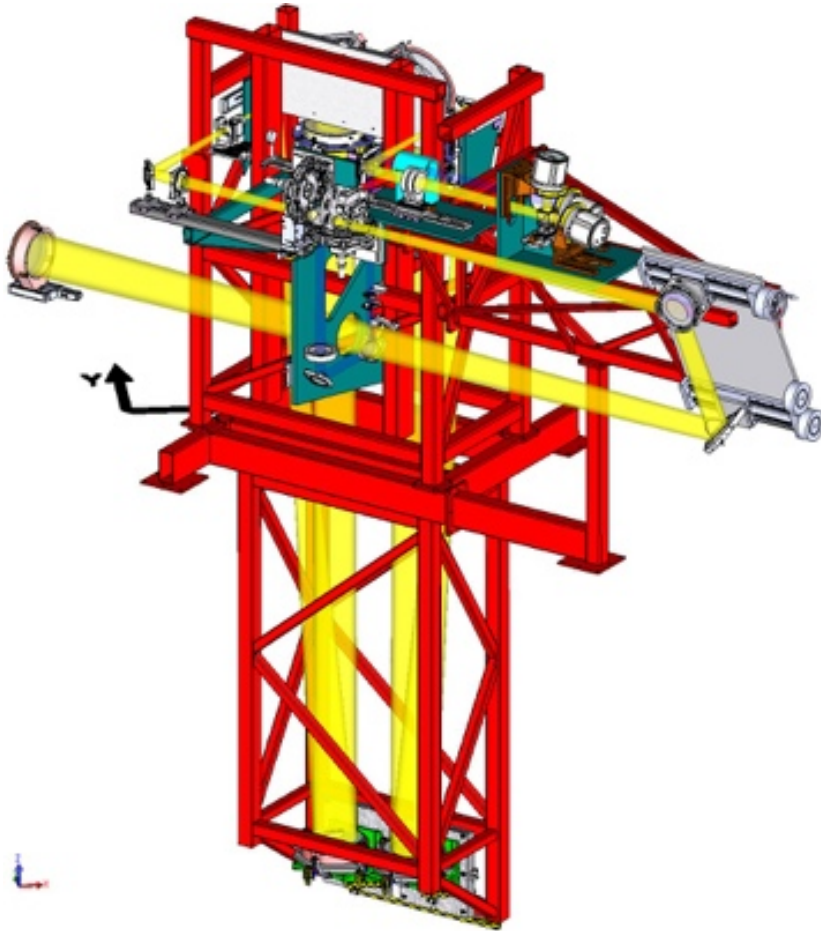

- Dual Fabry-Perot system for imaging spectro-polarimetry (300 mm FP).
- Spectral range: 520 – 870 nm. First light filters: NaD1, FeI 630.2nm, H-alpha, CaII 854.2 nm
- Sequential selection of filters/sampling wavelengths.
- Simultaneous broad-band images.
- Dual beam spectropolarimeter; orthogonal polarization states are imaged on two separate detectors.
- At first light, only one etalon will be available: limited sampling for broad (chromospheric) lines.

Visible Tunable Filter (VTF)

Instantaneous Field of View:

60 x 60 arcsec²

Spatial sampling:

0.014 arcsec/pixel

Spectral Resolution:

6 pm FWHM (@600 nm), $R \sim 100000$

Temporal Sampling:

1-2 s per line scan (spectroscopy)

5-10 s per line scan (polarimetry)

Polarimetric Capability:

Full Stokes vector polarimetry

Target Sensitivity: $3 \times 10^{-3} P/I_{\text{cont}}$

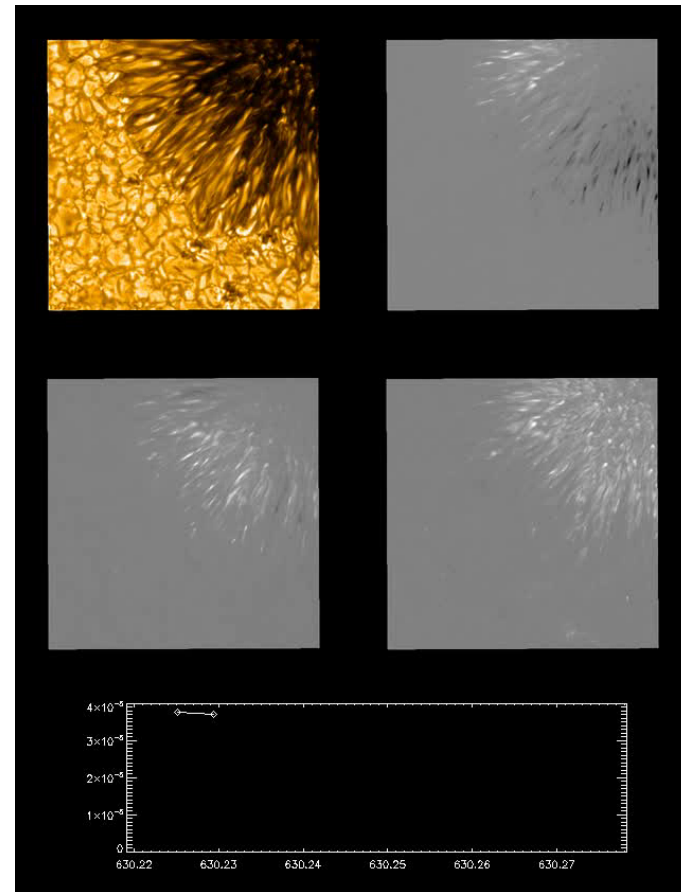

VTF will have very high spatial resolution, and allow rapid imaging spectrometry, Stokes imaging polarimetry, and accurate surface photometry

Diffraction Limited Near-IR Spectropolarimeter (DL-NIRSP)

*First facility class
integral field
spectropolarimeter for
solar physics.
Simultaneous spectral
and 2d spatial
coverage.*

UH/IfA (PI: Haosheng Lin)

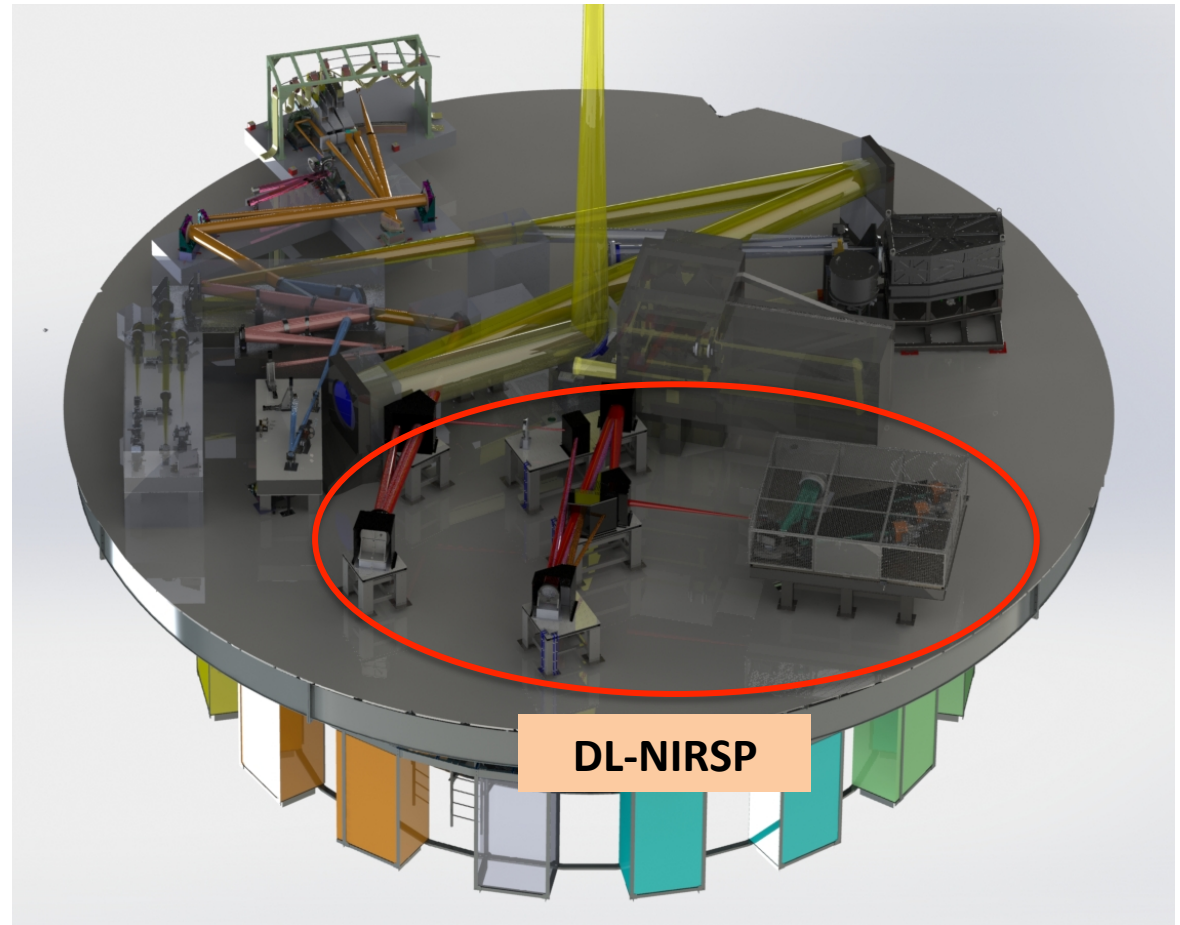
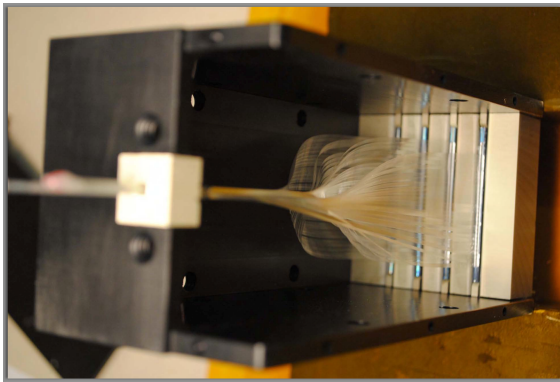

Diffraction Limited Near-IR Spectropolarimeter (DL-NIRSP)

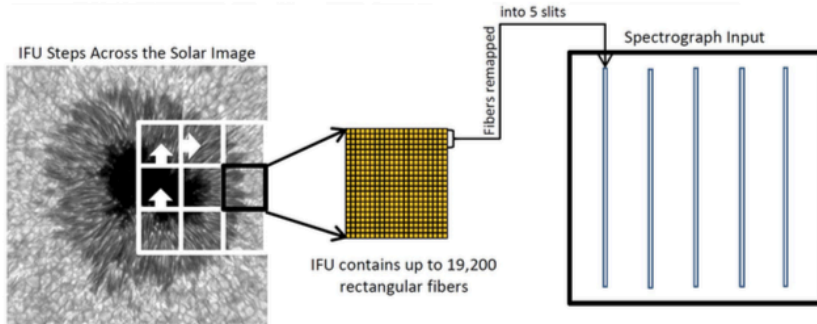

One tile at a time, DL-NIRSP builds spectropolarimetric full data cubes: [X ; Y ; λ ; S [I,Q,U,V] ; t]

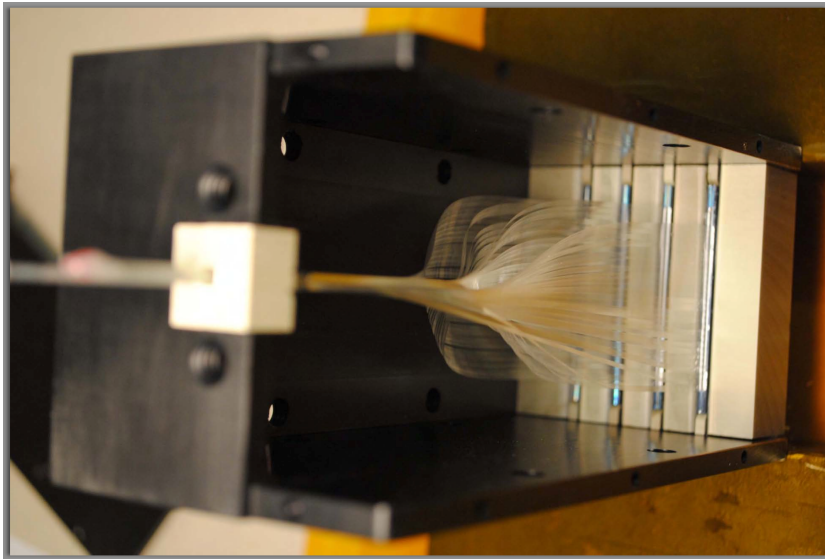

- Diffraction grating based Integral Field Spectrograph.
- Spectral range: 500 -1800 nm.
- 3 synchronized co-operating channels:
 - 500-900 nm
 - 900-1350 nm
 - 1350-1800 nm
- Only one spectral band ($\sim 1-2$ nm) per channel can be observed. First light filters:
 - Fe I 630.2 nm;
 - Fe XI 789.2 ; Ca II 854.2;
 - Fe XIII 1074.7 ; He I 1083.0;
 - Si X 1430 ; Fe I 1565 nm
- Dual beam polarimetry.

Diffraction Limited Near-IR Spectropolarimeter (DL-NIRSP)

Instantaneous Field of View:

2.4 x 1.8 arcsec² (high-res.)

6.16 x 4.62 arcsec² (med-res.)

27.84 x 18.56 arcsec² (wide field)

Full optical field:

2 x 2 arcmin – by field sampling

Spatial sampling:

0.03, 0.077, 0.464 arcsec

Spectral Resolution:

R = 125000

Temporal Sampling:

0.03 – 10 seconds / tile

Polarimetric Capability:

Full Stokes Vector Polarimetry (Dual Beam)

Target Sensitivity: $> 5 \times 10^{-4} P/I_{\text{cont}}$

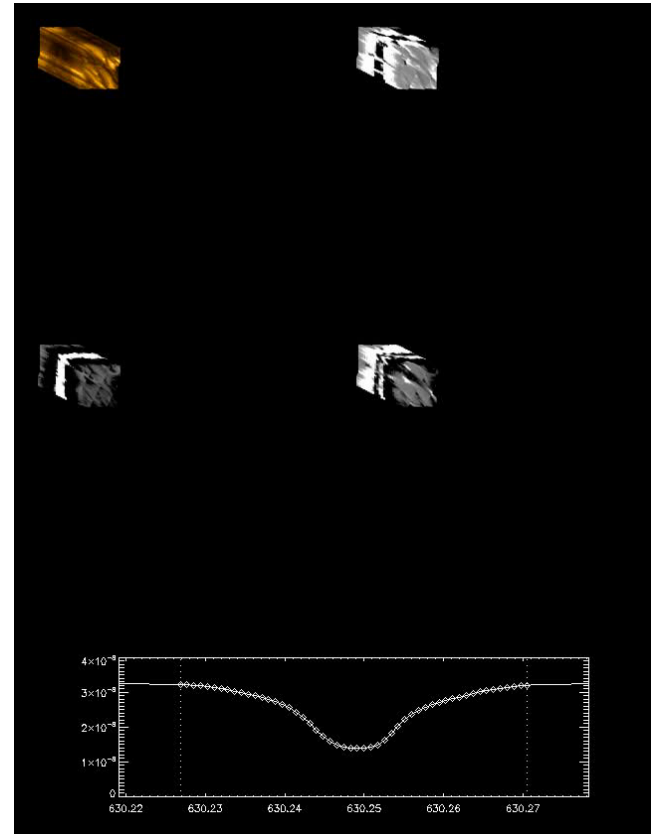

DL-NIRSP provides simultaneous spatial and spectral coverage over small-moderate FOVs, while maintaining high spatial resolution, spectral resolution, and polarimetric accuracy

Cryogenic Near-IR Spectropolarimeter (Cryo-NIRSP)

Facility-class near-IR cryogenic slit-based spectrograph optimized for background-limited coronal and near-IR observations.

UH/IfA (PI: Jeff Kuhn)

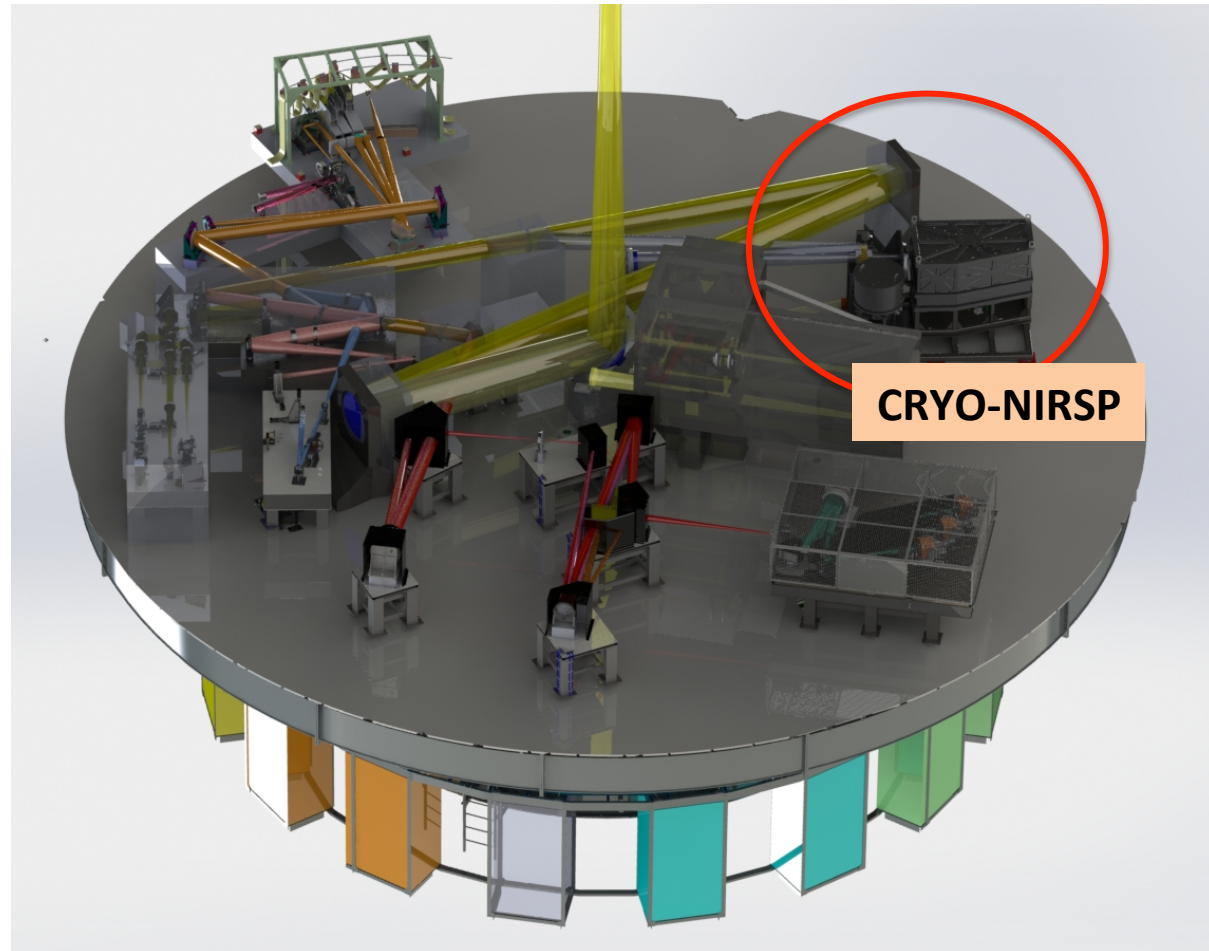

Cryogenic Near-IR Spectropolarimeter (Cryo-NIRSP)

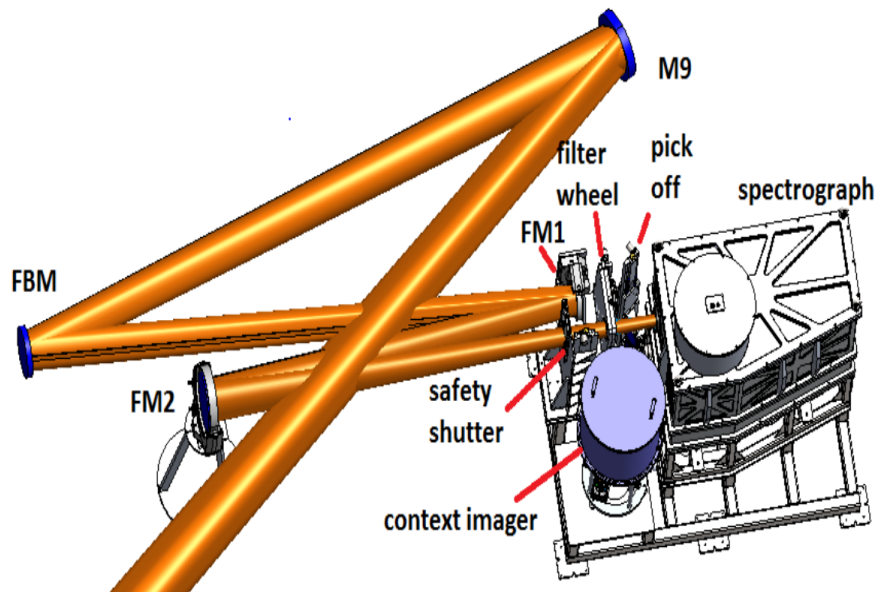

- Cryogenic: optimized for coronal observations (low background)
- Diffraction grating based spectrograph. Near IR range: 1000 – 5000 nm.
- Need order sorting filters (20-100 nm wide, λ -dependent). Six are currently available: diagnostics from 5,000 to 2MK
- 2 slit widths: 0.15" and 0.5" (nominal: on disk and off-limb)
- Dual beam polarimetry
- Context imager (100"x100")

Cryogenic Near-IR Spectropolarimeter (Cryo-NIRSP)

Instantaneous Field of View:

0.15" x 2' (on-disk)

0.5" x 4' (corona)

Full optical field (by slit scanning):

2 x 2 arcmin² – on disk

4 x 3 arcmin² – coronal mode

Spatial sampling:

0.12" along slit; 0.052" Context imager

(No AO: stability better than 1")

Spectral Resolution:

R = 100,000 (Disk);

R = 30,000 Coronal Mode:

Polarimetric Capabilities:

Full Stokes Polarimetry (Dual Beam)

Target Sensitivity: $5 \times 10^{-4} P/I_{\text{cont}}$

Context imager (100" x 100") centered on the slit.

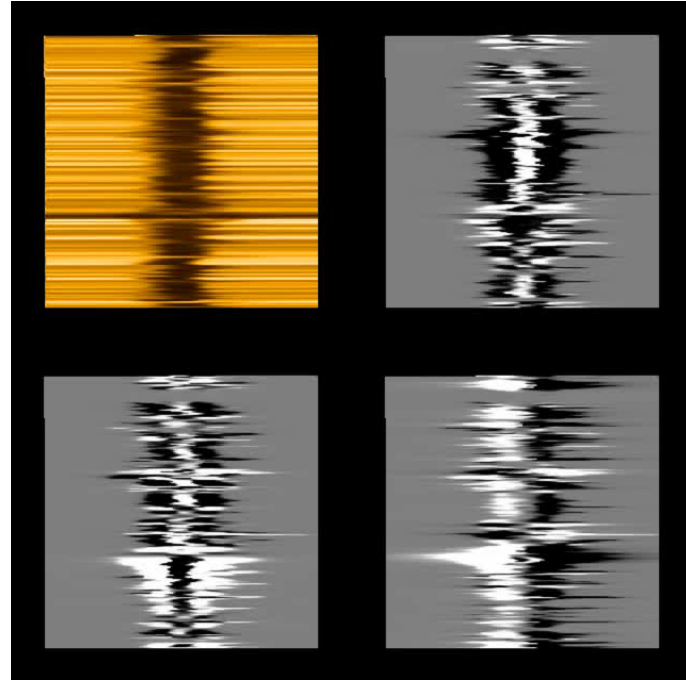

Cryo-NIRSP is optimized for coronal observations in novel, IR diagnostics. Operation flexibility serves wide range of exploratory science

FOV of Instruments – on-disk example

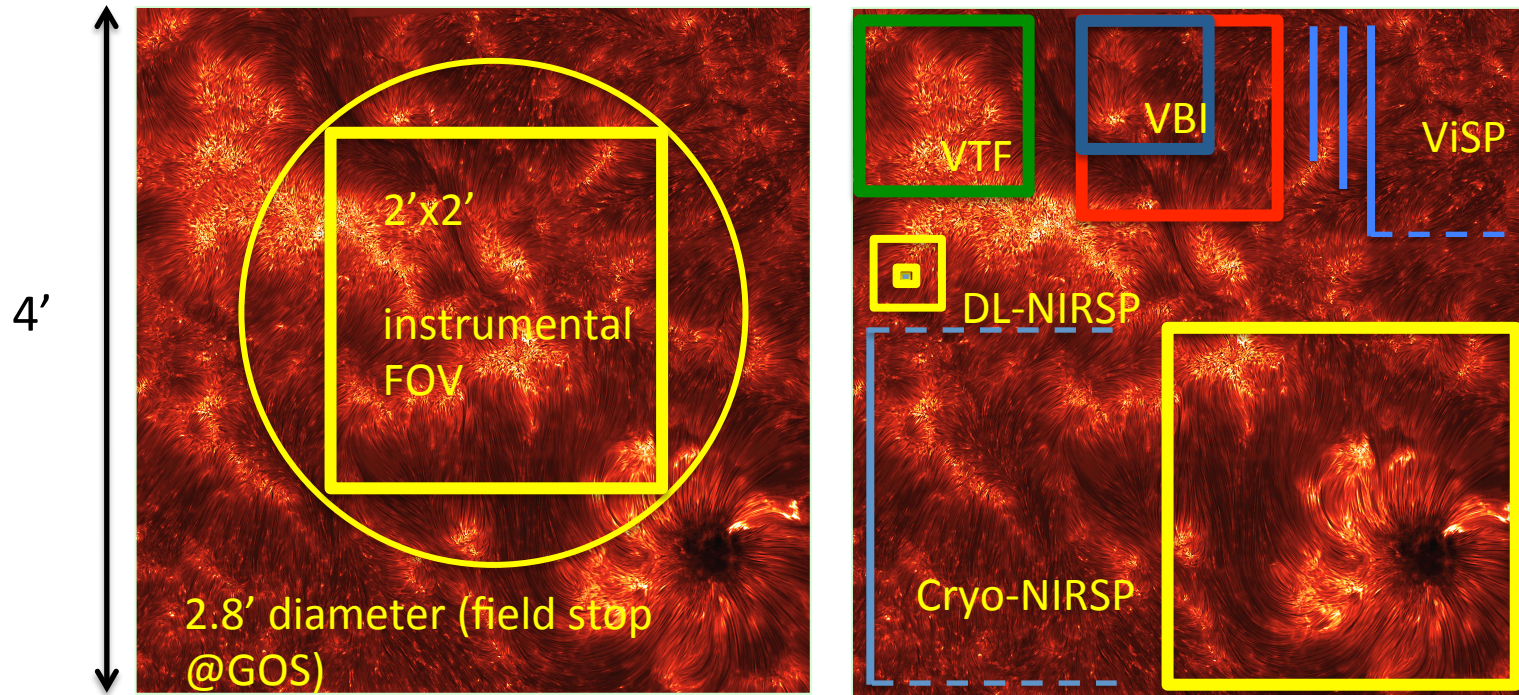

Note: Cryo is a standalone instrument

Note: instruments co-point on Sun !

FOV of Instruments: Limb example

5 arcmin occulter

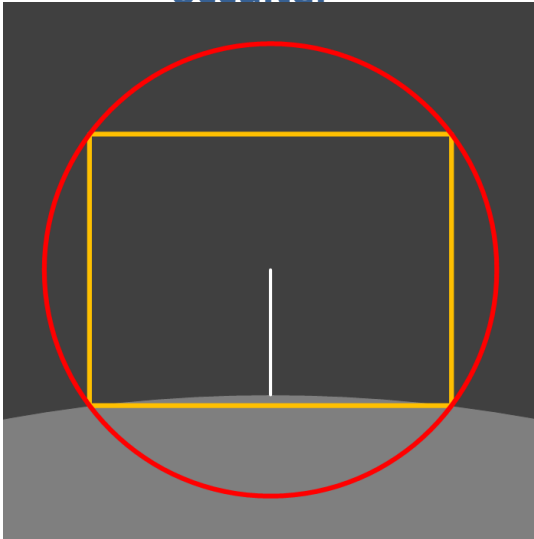

- Cryo-NIRSP: -7.5 arcsec above limb.
- FOV center to disk: 82 arcsec.

2.8 arcmin occulter

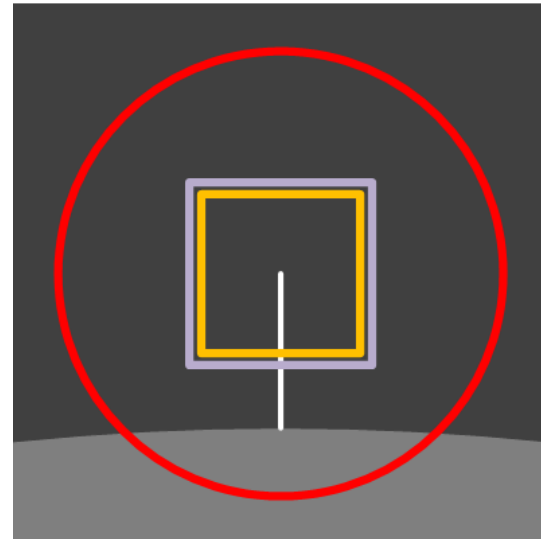

- VBI Red [Fe XI 789 nm]: 24 arcsec above limb.
- VTF: 28 arcsec above limb.
- FOV center to disk: 58 arcsec.

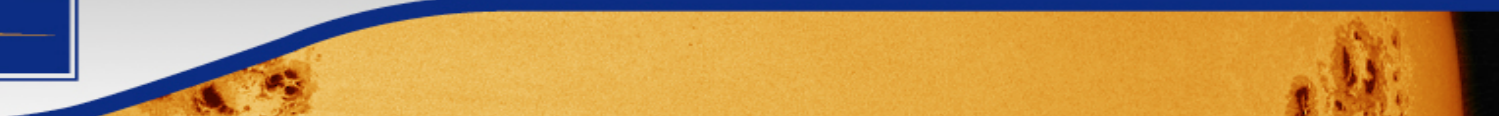

Thanks !



<http://dkist.nso.edu/>

Observing Conditions

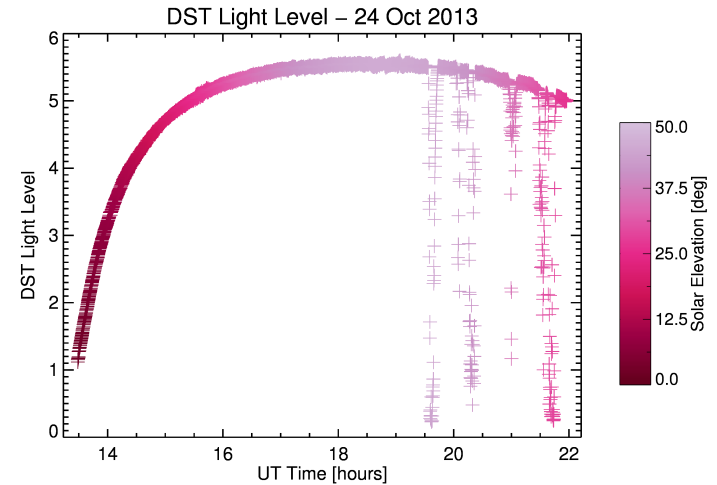
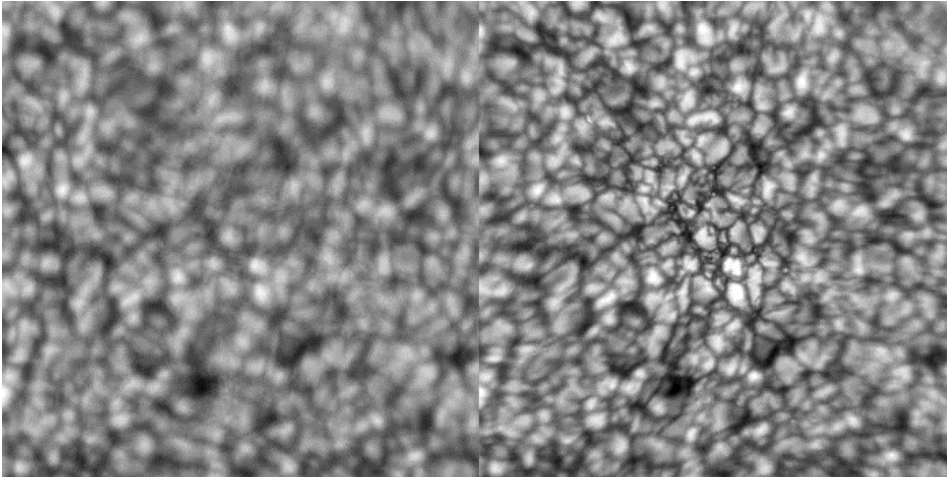

- Seeing: fluctuates in time and within the FOV of instruments (even with AO); wavelength dependent.
- Light-level (sky transparency) fluctuations (clouds).



The DKIST: status and timeline

DKIST Construction Project Summary Schedule

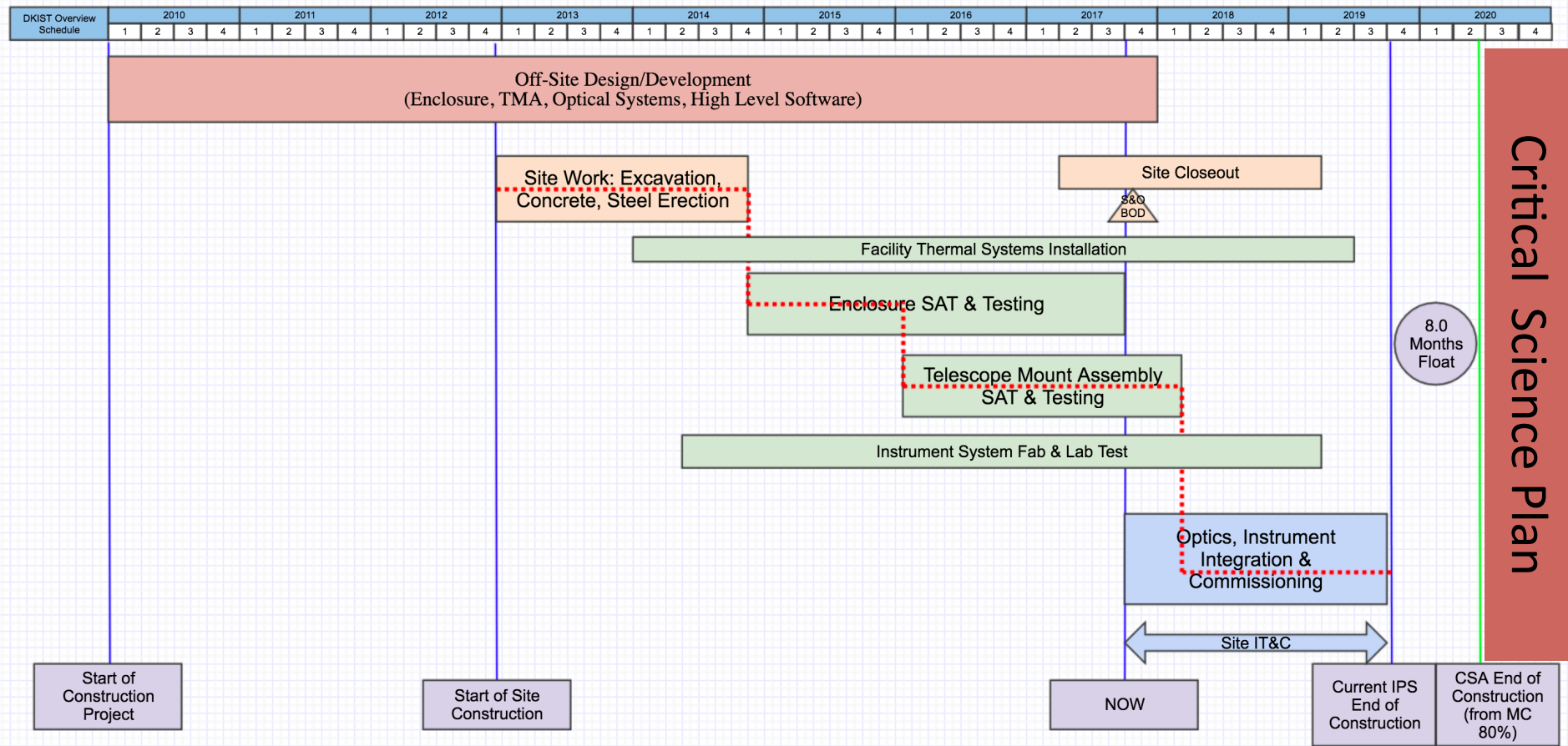

8 years of construction; 80% complete